



Standard Bellows Metering Pumps

The Pump People

Bellows Metering Pumps operate on a positive displacement principle. Pumps are designed to displace both corrosive and noncorrosive fluids. Accurate to $\pm 0.5\%$ from stroke to stroke, when pump is set 50% to 100% of full stroke. Discharge pressure is maintained over the entire flow range of the pump.

Poppet valves are used to prevent back flow; and springs are available to provide a positive shutoff, preventing siphoning through the pump in applications where a positive suction head exists.

Typical applications include film and x-ray processors, silver recovery systems, wafer and silicon chip washers and processors, detergent dispensers, blood analyzing equipment, industrial floor scrubbers, thermo therapy equipment, waste removal systems, and wastewater and water treatment systems.

Features:

- Repeatability from stroke-to-stroke to $\pm 0.5\%$
- Dry run capability
- Self-priming
- No dynamic seals
- Corrosion resistant
- Long, maintenance-free operation

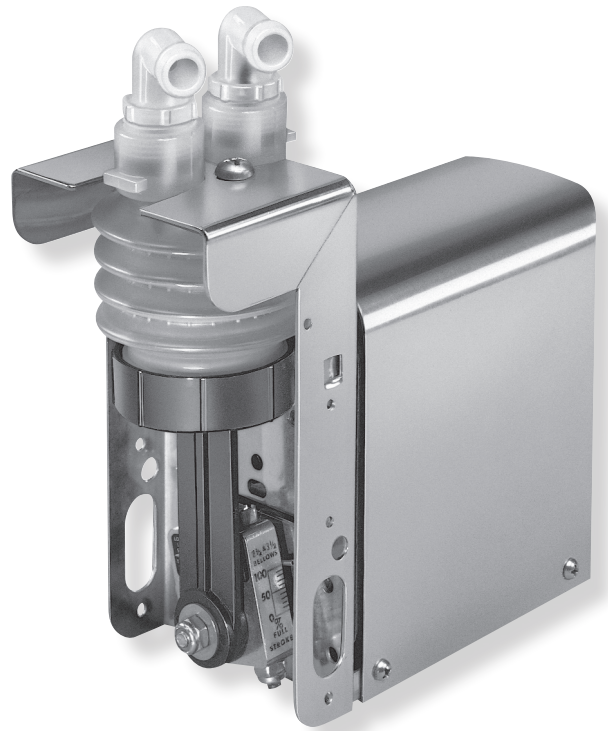

Contents

	Pages
• Overview	2-4
• Pump Selection	5-16
• Part Selection Guide	17
• Options.....	18
• Accessories	19
• Replacement Kits	20-23





The Pump People

Standard Bellows Metering Pumps Overview

Bellows metering pumps operate on a positive displacement principle. Pumps are designed to displace both corrosive and noncorrosive fluids. Accurate to $\pm 0.5\%$ from stroke to stroke, when pump is set 50% to 100% of full stroke. Discharge pressure is maintained over the entire flow range of the pump. Poppet valves are used to prevent back flow; and springs are available to provide a positive shutoff, preventing siphoning through the pump in applications where a positive suction head exists.

Features:

- Repeatability from stroke-to-stroke to $\pm 0.5\%$
- Dry run capability
- Self-priming
- No dynamic seals
- Corrosion resistant
- Long, maintenance-free operation

Typical applications include film and x-ray processors, silver recovery systems, wafer and silicon chip washers and processors, detergent dispensers, blood analyzing equipment, industrial floor scrubbers, thermo therapy equipment, waste removal systems, and wastewater and water treatment systems.

Bellows Metering Pump Operation:

The Bellows Metering Pumps operate on a positive displacement principle. The rotation of the motor shaft is transmitted into an up and down motion through a lever pivot crank mechanism. This motion provides a continuous squeezing and relaxing force on a bellows module, forcing fluid in and out of the module. Discharge pressure is maintained over the entire flow range of the pump.

Optimum Operating Conditions:

Optimum operating conditions consists of a 6" minimum suction lift and a discharge head of not less than 6". Pumps must be mounted vertically with the valve body at the top to obtain maximum metering accuracy.





The Pump People

Flow Rate and Discharge Pressure

The flow rate of each bellows module is regulated by three factors:

1. Diameter of the bellows,
2. Speed of the gear motor,
3. Adjustment of the module stroke length.

Bellows are available in several different diameters.

The full stroke displacement and discharge pressure of the pump is dependent on the size of the bellows as shown below:

Size	1/2"	1"	1 1/2"	2 1/2" STD	2 1/2" BOJ
Full Stroke Displacement in ml	.5	5	10.5	55	27.5
Maximum Discharge Pressure (psi)	50	40	20	5	5

Flow Adjustment:

The flow rate of all bellows pumps can be adjusted by modifying the length of the discharge stroke. Adjustments can be made down to 10% of full stroke on all models except 1/2" models which are limited to 20% of full stroke. Two styles of adjustment mechanisms are available.

Note: Best priming and metering accuracy occurs when the stroke length is 50% or greater.

Standard Crank — Adjustment cannot be made while pump is operating. An adjusting screw changes the stroke length of an eccentric crank.

BEL O JUST® — Can be adjusted while the pump is operating. A knob regulates drive arm motion which modifies the stroke length of the bellows module.





The Pump People

Pump Specifications:

Flow Rates — Range from 3.9 ml/min to 3000 ml/min, depending on pump configuration, gearmotor speed and stroke length.

Discharge Pressures — Range from 5 to 50 psi depending on bellows size.

Max Fluid Temperature — 140°F (60°C) Note: Reduce pressure rating by 50% for fluid temperatures over 120°F (49°C).

Viscosity/Slurries — Maximum fluid viscosity is 5,000 centistokes. Poppet valves can handle fine slurries. Duckbill valves are recommended for heavy slurries or fibrous materials. **Heavy slurries should be flushed from the pump before shutdown.**

MAXIMUM DRY AND WET PRIMING SPECIFICATIONS				
Feet (Meters)				
Bellows Sizes	Dry Prime 50% of Full Stroke	Dry Prime 100% of Full Stroke	Wet Prime 50% of Full Stroke	Wet Prime 100% of Full Stroke
1/2"	2.5 (.76)	8.67 (2.64)	5.83 (1.78)	17.17 (5.23)
1"	3.08 (.94)	8.33 (2.54)	6.25 (1.91)	14.25 (4.34)
1 1/2"	4.33 (1.32)	11.00 (3.35)	9.58 (2.92)	20.58 (6.27)
2 1/2"	9.17 (2.80)	18.50 (5.64)	15.25 (4.65)	27.58 (8.41)

Gearmotors:

Catalog gear motors are available in 115V, 50/60 Hz or 240V, 50/60 Hz. Standard motor speeds are 39, 60, 90 and 165 RPM at 60 Hz. Motors are UL recognized and continuous duty rated with a minimum life expectancy of 2000 hours. Perpetual running of motor is not recommended. If a non-stop application is required, the Gorman-Rupp Industries Heavy-Duty Bellows Metering Pump is recommended.

Materials in Contact with Solution:

Connectors — Polypropylene

O-Rings (Elastomers) — EPT/EPDM or Viton®/Fluoroelastomer

Poppet/Duckbill Valves — EPT/EPDM or Viton®/Fluoroelastomer

Bellows — Standard Polypropylene Materials

Additional materials available, refer to OEM Section.

Pump Selection:

From the following pages (5-16) select a bellows size that meets your pressure requirements. Select a model with the bellows size that provides your required flow while operating closest to full stroke capacity (See **Flow Adjustment** on page 4). Best metering accuracy occurs when bellows modules operate at 50% or more of maximum output. For 24 hour continuous duty service, use one of the heavy-duty models.

Select a valve and O-ring combination and tubing connectors for each bellows from the **Part Selection Guide**, page 17. Specify duckbill valves if heavy slurries or fibrous materials are being pumped. Refer to the Chemical Resistance Section to help determine compatibility.



Single Bellows Pumps Standard & BEL 0 JUST Models

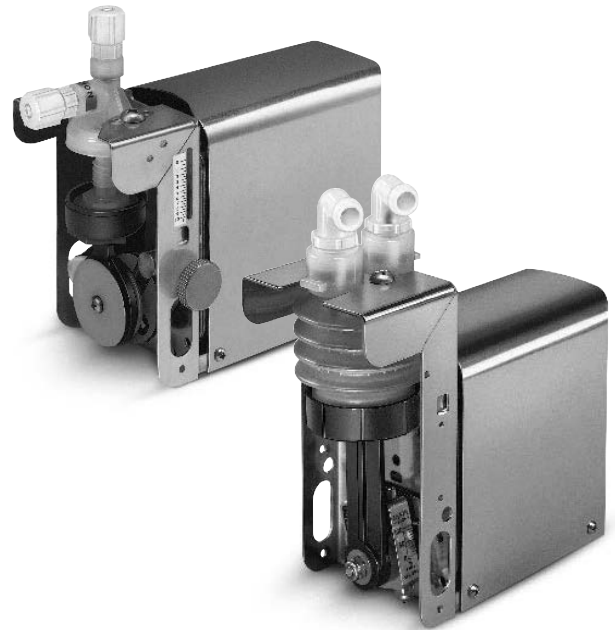

Order notes: When ordering a single bellows model, add one “X” code for valve and O-ring material selection and one “T” code for connector selection from the Bellows Part Selection Guide on page 16.

Example: 13300-007 (1” bellows model) with EPT/EPDM poppet valves and O-rings and elbow connectors for 3/8” I.D. Tubing would be ordered as 13300-007 X-112 T-008.

MODEL SPECIFICATIONS

Standard Single Model Number		BEL 0 JUST® Model Number		Bellows	Discharge Strokes per minute (Motor RPM)		Maximum Flow ml per minute per module		Gallons (Liters) per hour per module		Max. Pressure	Electrical Amps*	Approx. Wt.
120V/60 Hz	240V/60 Hz	120V/60 Hz	240V/60 Hz	Diameter Inches	50 Hz	60 Hz	50 Hz	60 Hz	50 Hz	60 Hz	PSI (kg/cm2)	120V 60 Hz	lbs.
110V/50 Hz	220V/50 Hz	110V/50 Hz	220V/50 Hz										
13960-022	13960-024	14280-006	14280-007	½	32.5	39	16.3	19.5	6.2 for 24 hrs. (23.4)	7.4 for 24 hrs. (28.1)	50 (3.7)	1.1	5.5
13960-027	13960-028	14280-009	14280-014	½	137	165	68.8	82.5	26.1 for 24 hrs. (99.0)	31.4 for 24 hrs. (118.8)	50 (3.7)	1.1	5.5
13300-007	13300-008	14250-005	14250-006	1	32.5	39	162.5	195	2.6 (9.8)	3.1 (11.7)	40 (2.9)	1.1	5.5
13300-009	13300-010	14250-007	14250-008	1	50	60	250.0	300	4.0 (15.0)	4.8 (18.0)	40 (2.9)	1.3	5.5
13300-045	13300-046	14250-014	14250-015	1	75	90	375.0	450	5.9 (22.5)	7.1 (27.0)	40 (2.9)	1.1	5.5
13300-047	13300-048	14250-016	14250-017	1	137	165	687.5	825	10.9 (41.2)	13.1 (49.5)	20 (1.5)	1.1	5.5
13325-001	13325-002	14251-001	14251-002	1½	32.5	39	341.3	409.5	5.4 (20.5)	6.5 (24.6)	20 (1.5)	1.1	5.5
13325-003	13325-004	14251-003	14251-004	1½	50	60	525.0	630	8.3 (31.5)	10.0 (37.8)	20 (1.5)	1.3	5.5
13325-005	13325-006	14251-005	14251-006	1½	75	90	787.0	945	12.5 (47.2)	15.0 (56.7)	20 (1.5)	1.1	5.5
13325-031	13325-032	14251-007	14251-008	1½	137	165	1443.8	1732.5	22.8 (86.6)	27.5 (103.9)	10 (.73)	1.1	5.5
12950-003	12950-004	N/A	N/A	2½	32.5	39	1787.5	2145	28.3 (107.3)	34.0 (128.7)	5 (.37)	1.1	5.5

*Amp values for 240V will be approximately 50% of 120V values shown above.

Typical Dimensions

Single Bellows Pumps

Standard & BEL 0 JUST Models

1/2" Model

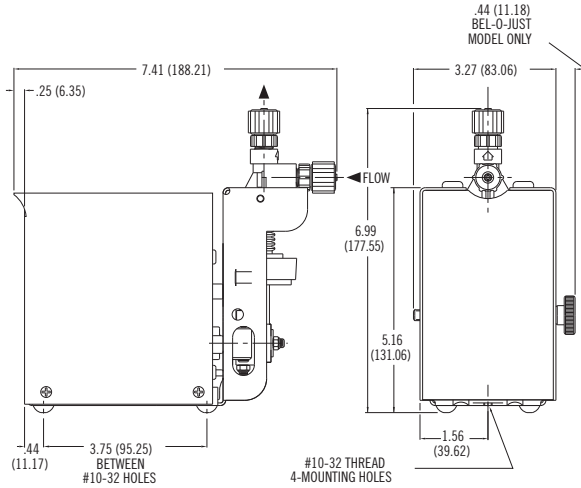

1" Model

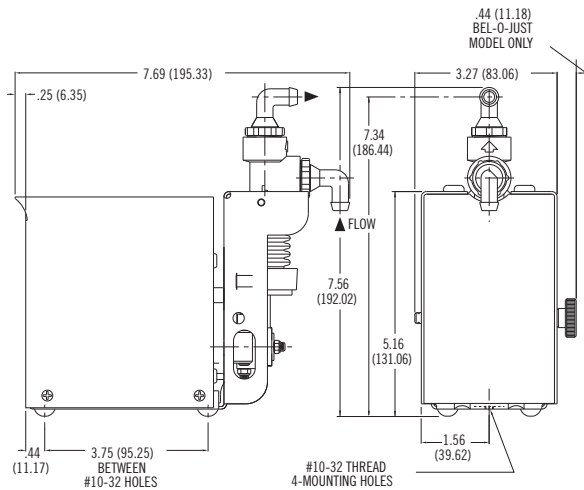

1 1/2" Model

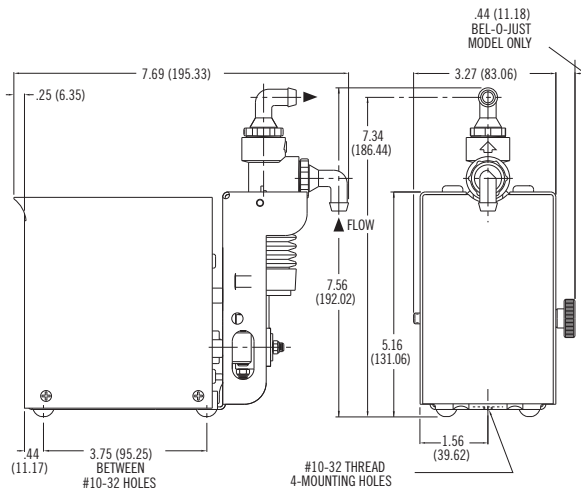

2 1/2" Model

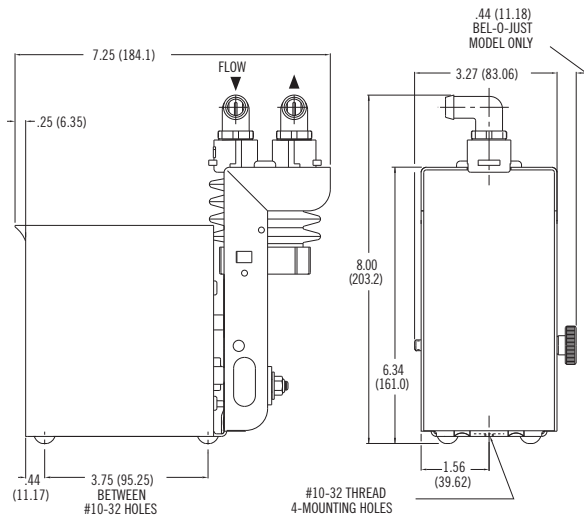

Dimensions in Inches
(Dimensions in Millimeters)



Two Tandem Bellows Pumps Standard & BEL O JUST Models

Two tandem bellows pumps feature modular design for proportioning separate liquids. The flow rate of each bellows module is independently adjustable. Bellows modules are assembled out-of-phase for most efficient power usage. Total output of pump is limited to 3,000 ml/min.

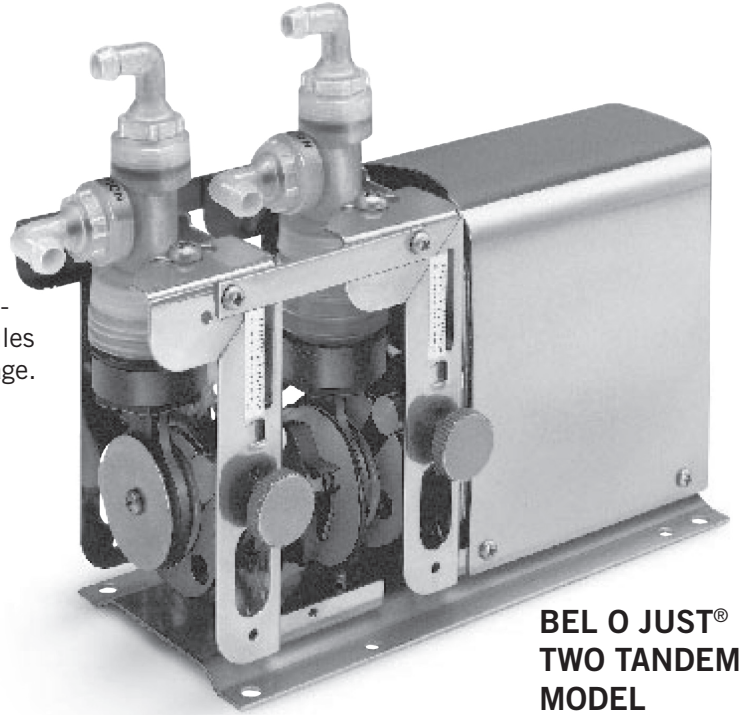

**BEL O JUST®
TWO TANDEM
MODEL**

Order notes: When ordering a two tandem bellows model, add one “X” code for valve and O-ring material selection and one “T” code for connector selection from the Bellows Part Selection Guide on page 16.

Example: 13726-014 (1½” x 1½” two tandem model) with EPT/EPDM poppet valves and O-rings and elbow connectors for 3/8” I.D. tubing would be ordered as 13726-014 X-115 T-008 X-112 T-008.

MODEL SPECIFICATIONS

Standard Single Model Number		BEL O JUST® Model Number		Bellows Diameter Inches	Discharge Strokes per minute (Motor RPM)		Maximum Flow ml per minute per module		Gallons (Liters) per hour per module		Max. Pressure PSI (kg/cm²)	Electrical Amps* 120V 60 Hz	Approx. Wt. lbs.
120V/60 Hz 110V/50 Hz	240V/60 Hz 220V/50 Hz	120V/60 Hz 110V/50 Hz	240V/60 Hz 220V/50 Hz		50 Hz	60 Hz	50 Hz	60 Hz	50 Hz	60 Hz			
13701-021	13701-022	14324-029	14324-030	1 x 1	50	60	250.0/ 250.0	300.0/ 300.0	3.96/3.96 (15.0/15.0)	4.75/4.75 (18.0/18.0)	20/20 (1.50/1.50)	1.1	7.5
13701-019	13701-020	14324-027	14324-028	1 x 1	75	90	375.0/ 375.0	450.0/ 450.0	5.94/5.94 (22.5/22.5)	7.13/7.13 (27.0/27.0)	20/20 (1.50/1.50)	1.1	7.5
13726-016	13726-017	15904-003	15904-004	1½ x 1½	50	60	525.0/ 525.0	630.0/ 630.0	8.32/8.32 (31.5/31.5)	9.98/9.98 (37.8/37.8)	10/10 (.73/.73)	1.1	7.5
13726-014	13726-015	15904-001	15904-002	1½ x 1½	75	90	787.5/ 787.5	945.0/ 945.0	12.47/12.47 (47.2/47.2)	14.97/14.97 (56.7/56.7)	10/10 (.73/.73)	1.1	7.5

*Amp values for 240V will be approximately 50% of 120V values shown above.

Typical Dimensions

Two Tandem Bellows Pumps Standard & BEL 0 JUST Models

1" Model

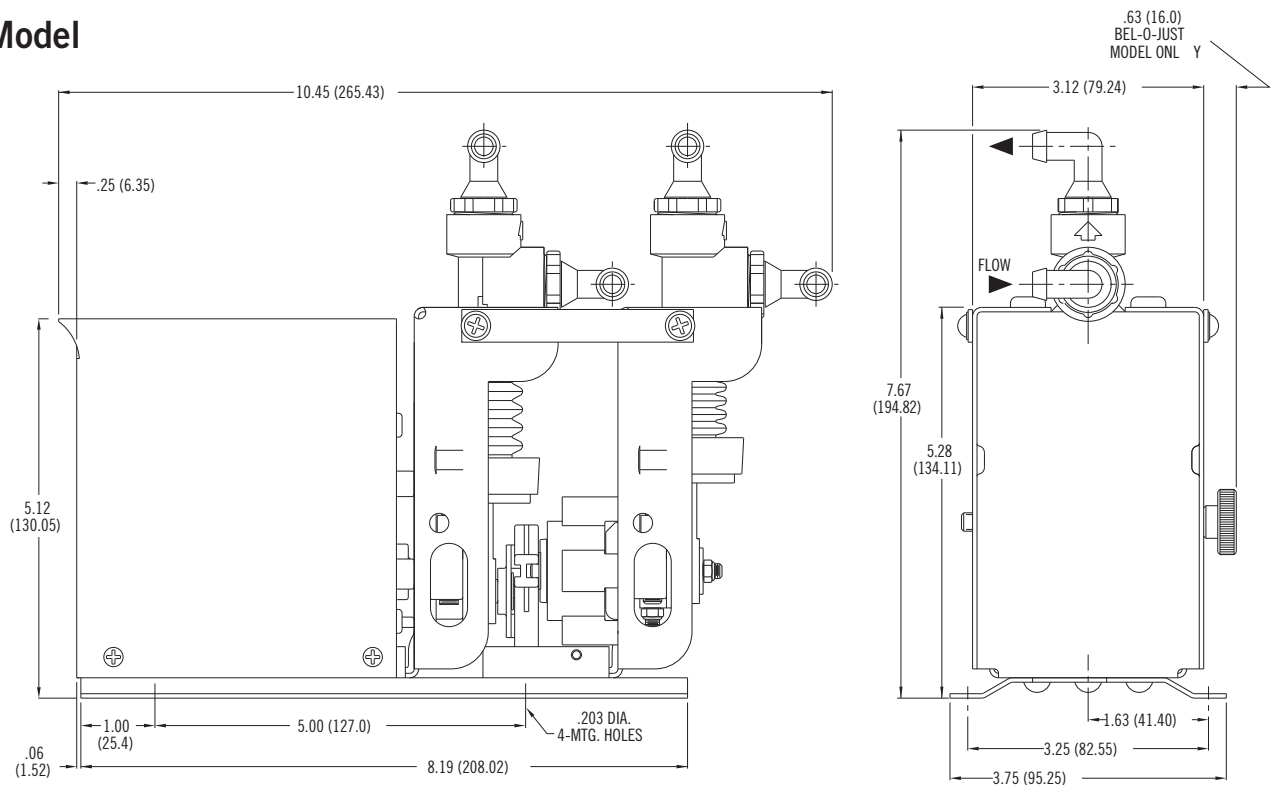

Dimensions in Inches
(Dimensions in Millimeters)

Three Tandem Bellows Pumps Standard & BEL O JUST Models

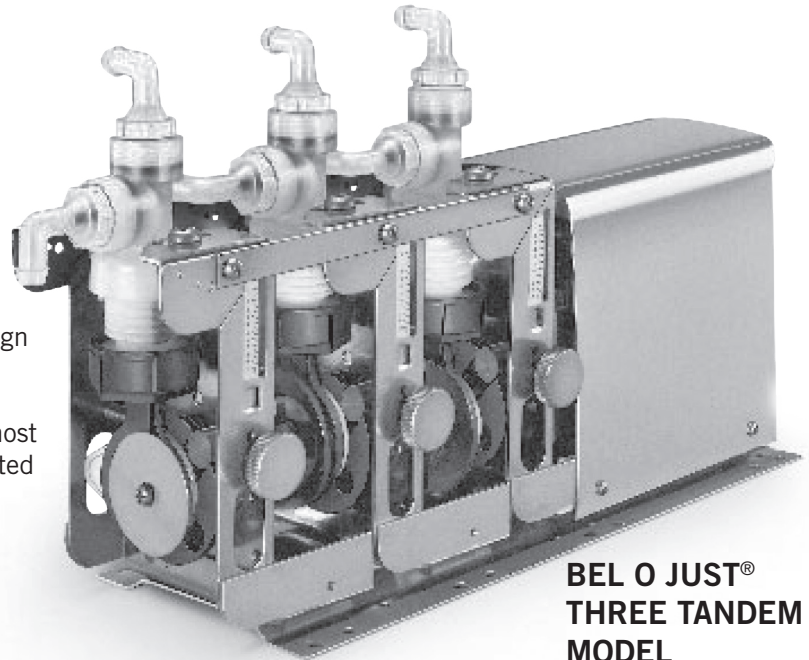

**BEL O JUST®
THREE TANDEM
MODEL**

Three tandem bellows pumps feature modular design for proportioning separate liquids. The flow rate of each bellows module is independently adjustable. Bellows modules are assembled out-of-phase for most efficient power usage. Total output of pump is limited to 3,000 ml/min.

Order notes: When ordering a three tandem bellows model, add one “X” code for valve and O-ring material selection and one “T” code for connector selection from the Bellows Part Selection Guide on page 16.

Example: 13700-011 (1” x 1” x 1” three tandem model) with EPT/EPDM poppet valves and O-rings and elbow connectors for 3/8” I.D. tubing would be ordered as 13700-011 X-112 T-008 X-112 T-008 X-112 T-008.

MODEL SPECIFICATIONS

Standard Single Model Number		BEL O JUST® Model Number		Bellows Diameter Inches	Discharge Strokes per minute (Motor RPM)		Maximum Flow ml per minute per module		Gallons (Liters) per hour per module		Max. Pressure PSI (kg/cm²)	Electrical Amps* 120V 60 Hz	Approx. Wt. lbs.
120V/60 Hz 110V/50 Hz	240V/60 Hz 220V/50 Hz	120V/60 Hz 110V/50 Hz	240V/60 Hz 220V/50 Hz		50 Hz	60 Hz	50 Hz	60 Hz	50 Hz	60 Hz			
13700-011	13700-012	14252-007	14252-008	1 x 1 x 1	50	60	250.0/ 250.0/ 250.0	300.0/ 300.0/ 300.0	4.0/4.0/4.0 (15.0/15.0/ 15.0)	4.8/4.8/4.8 (18.0/18.0/ 18.0)	20/20/20 (1.50/1.50/ 1.50)	1.1	9
13700-009	13700-010	14252-005	14252-006	1 x 1 x 1	75	90	375.0/ 375.0/ 375.0	450.0/ 450.0/ 450.0	5.9/5.9/5.9 (22.5/22.5/ 22.5)	7.1/7.1/7.1 (27.0/27.0/ 27.0)	20/20/20 (1.50/1.50/ 1.50)	1.1	9
13716-012	13716-013	15905-003	15905-004	1½ x 1½ x 1½	50	60	525.0/ 525.0/ 525.0	630.0/ 630.0/ 630.0	8.3/8.3/8.3 (31.5/31.5/ 31.5)	10.0/10.0 10.0 (37.8/37.8/ 37.8)	10/10/10 (.73/.73/ .73)	1.1	9
13716-009	13716-010	15905-001	15905-002	1½ x 1½ x 1½	75	90	787.5/ 787.5/ 787.5	945.0/ 945.0/ 945.0	12.5/12.5 12.5 (47.2/47.2/ 47.2)	15.0/15.0 15.0 (56.7/56.7/ 56.7)	10/10/10 (.73/.73/ .73)	1.1	9

*Amp values for 240V will be approximately 50% of 120V values shown above.

Typical Dimensions

Three Tandem Bellows Pumps Standard & BEL 0 JUST Models

1 1/2" Model

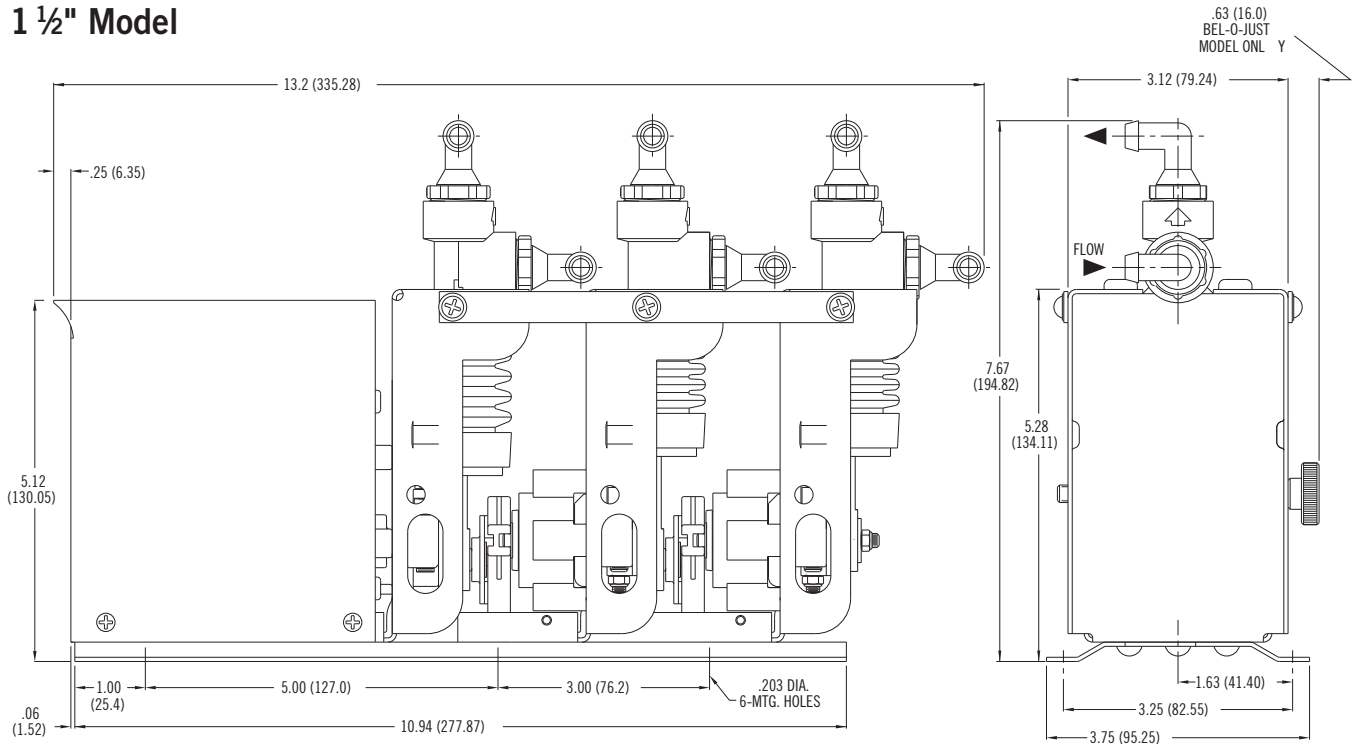

Dimensions in Inches
(Dimensions in Millimeters)

Single Stroke Dispensing Bellows Pumps

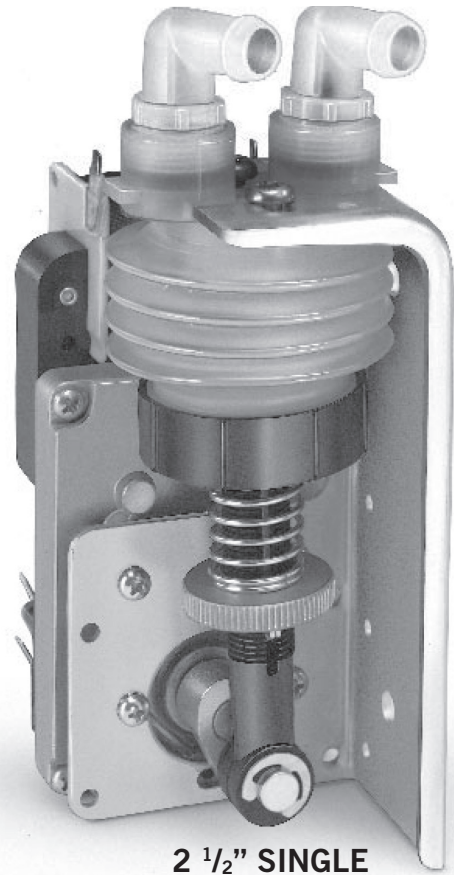

**2 1/2" SINGLE
STROKE MODEL**

Actuation of the single stroke dispensing pump is triggered by a switch. The crank makes one revolution before a microswitch interrupts the power circuit. Flow rates can be adjusted. Gearmotors on dispensing pump are rated for intermittent duty cycles.

Order notes: When ordering a single stroke model, add one "X" code for valve and O-ring material selection and one "T" code for connector selection from the Bellows Part Selection Guide on page 16.

Example: 12800-007 (2 1/2" bellows model) with EPT/EPDM poppet valves and O-rings and elbow connectors for 1/2" I.D. tubing would be ordered as 12800-007 X-122 T-009.

MODEL SPECIFICATIONS								
Dispensing Pump Model Number		Bellows Diameter Inches	Discharge Strokes per min. Motor RPM		Max. Flow ml per stroke	Max. Pressure	Electrical Amps*	Approx. Wt.
120V 50/60 Hz	240V 50/60 Hz		50 Hz	60 Hz		PSI (kg/cm ²)	120V 60 Hz	lbs.
15090-001	15090-002	1	8.3	10	5.0	40 (2.9)	.3	5
15090-003	15090-004	1 1/2	8.3	10	10.5	20 (1.5)	.3	5
12800-007	12800-026	2 1/2	8.3	10	55.0	5 (.37)	.3	5

*Amp values for 240V will be approximately 50% of 120V values shown above.



Typical Dimensions

Single Stroke Dispensing Bellows Pumps

1 1/2" Model

DIMENSIONS		
Pump Model	A	B
1" - 1 1/2"	8.3 (210.8)	3.45 (87.6)
2 1/2"	7.67 (194.8)	—

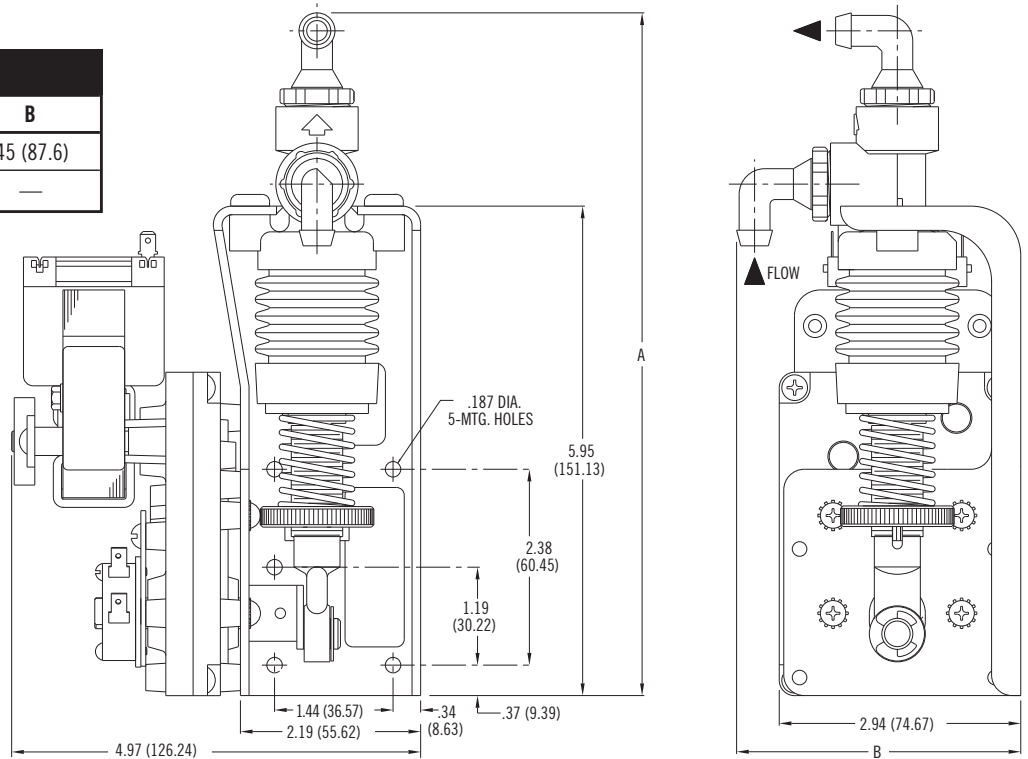

Dimensions in Inches
 (Dimensions in Millimeters)

The heavy-duty models are specially designed for use in dusty environments or for those applications requiring extremely long life. The pump is supplied with a totally enclosed gearmotor with an expected life of over 10,000 hours. The standard crank mechanism is used on heavy-duty pumps. The heavy-duty pump is recommended for 24 hour/day continuous duty applications.



2 1/2" HEAVY DUTY MODEL

Order notes: When ordering a heavy-duty model, add one "X" code for valve and O-ring material selection and one "T" code for connector selection from the Bellows Part Selection Guide on page 16.

Example: 15955-001 (1 1/2" bellows model) with EPT/EPDM poppet valves and O-rings and elbow connectors for 1/2" I.D. tubing would be ordered as 15955-001 X-112 T-009.

MODEL SPECIFICATIONS

Single Model Number		Bellows Diameter Inches	Discharge Strokes per minute (Motor RPM)		Maximum Flow ml per minute		Gallons (Liters) per hour		Max. Pressure PSI (kg/cm ²)	Electrical Amps* 115V 60 Hz	Approx. Wt. lbs.
115V/60 Hz	240V/60 Hz 220V/50 Hz		50 Hz	60 Hz	50 Hz	60 Hz	50 Hz	60 Hz			
15955-001	15955-002	1 1/2	83	100	872	1,050	13.8 (52.3)	16.6 (63)	20 (1.5)	.6	6
15956-001	15956-002	2 1/2	42	50	2,310	2,750	36.6 (138.6)	43.6 (165)	5 (.37)	.6	6

Typical Dimensions

Heavy Duty Bellows Pumps

1 1/2" Model

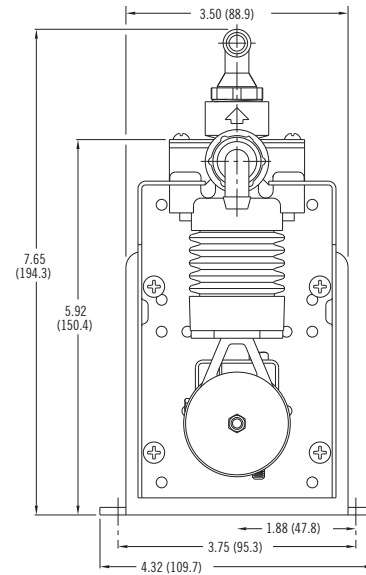
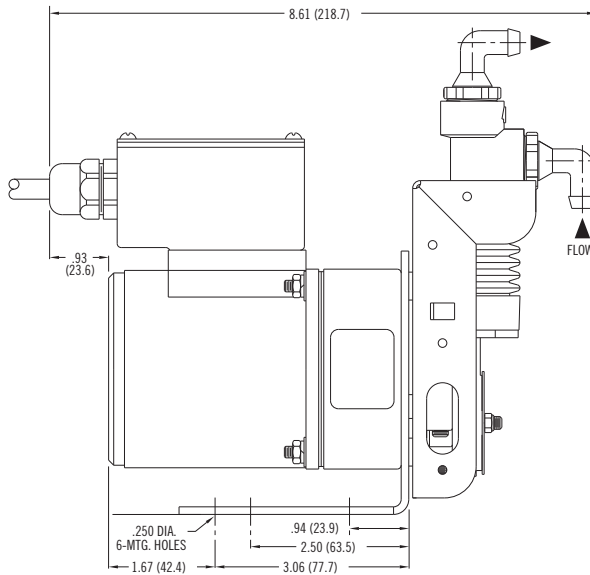

2 1/2" Model

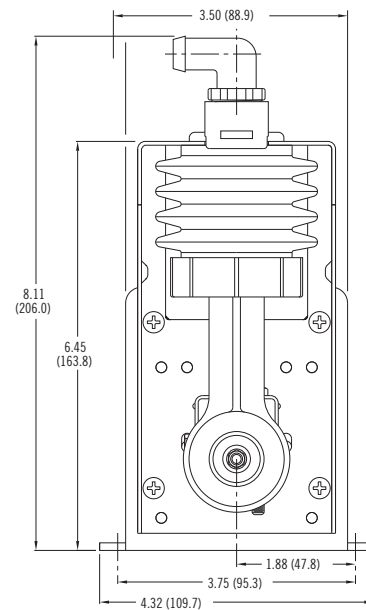
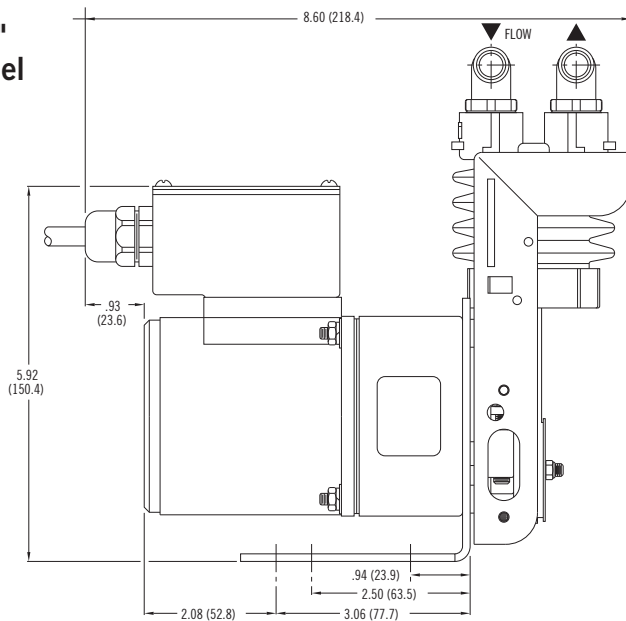

Dimensions in Inches
 (Dimensions in Millimeters)



The Dial-A-Flow® pump is supplied with an adjustable speed motor. Infinite speed adjustments can be made from 3 to 60 RPM. Speed control and adjustment of stroke length can be utilized to obtain desired flow rate. The Dial-A-Flow® pump uses a standard crank mechanism.

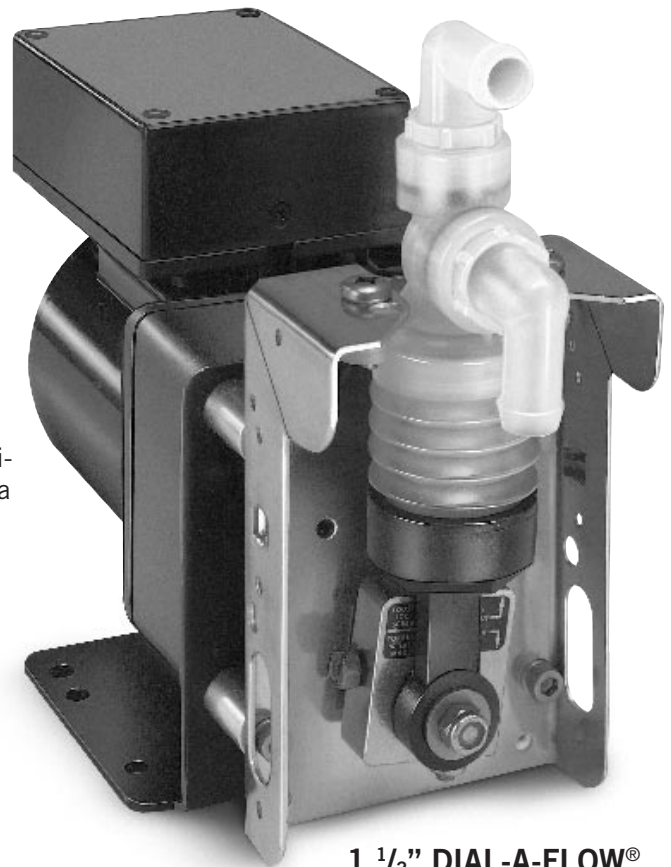

**1 1/2" DIAL-A-FLOW®
MODEL**

Order notes: When ordering a Dial-A-Flow® model, add one "X" code for valve and O-ring material selection and one "T" code for connector selection from the Bellows Part Selection Guide on page 16.

Example: 15950-001 (1 1/2" bellows model) with EPT/EPDM poppet valves and O-rings and elbow connectors for 1/2" I.D. tubing would be ordered as 15950-001 X-112 T-009.

MODEL SPECIFICATIONS

Single Model Number		Bellows	Discharge Strokes per minute (Motor RPM)		Maximum Flow ml per minute		Gallons (Liters) per hour		Max. Pressure	Electrical Amps*	Approx. Wt.
115V/60 Hz	220V/50 Hz	Diameter Inches	50 Hz	60 Hz	50 Hz	60 Hz	50 Hz	60 Hz	PSI (kg/cm ²)	115V 60 Hz	lbs.
15950-001	N/A	1 1/2	50	60	525	630	8.3 (31.5)	10 (37.8)	20 (1.5)	.85	6

Typical Dimensions

Dial-A-Flow[®] Bellows Pumps

1 1/2" Model

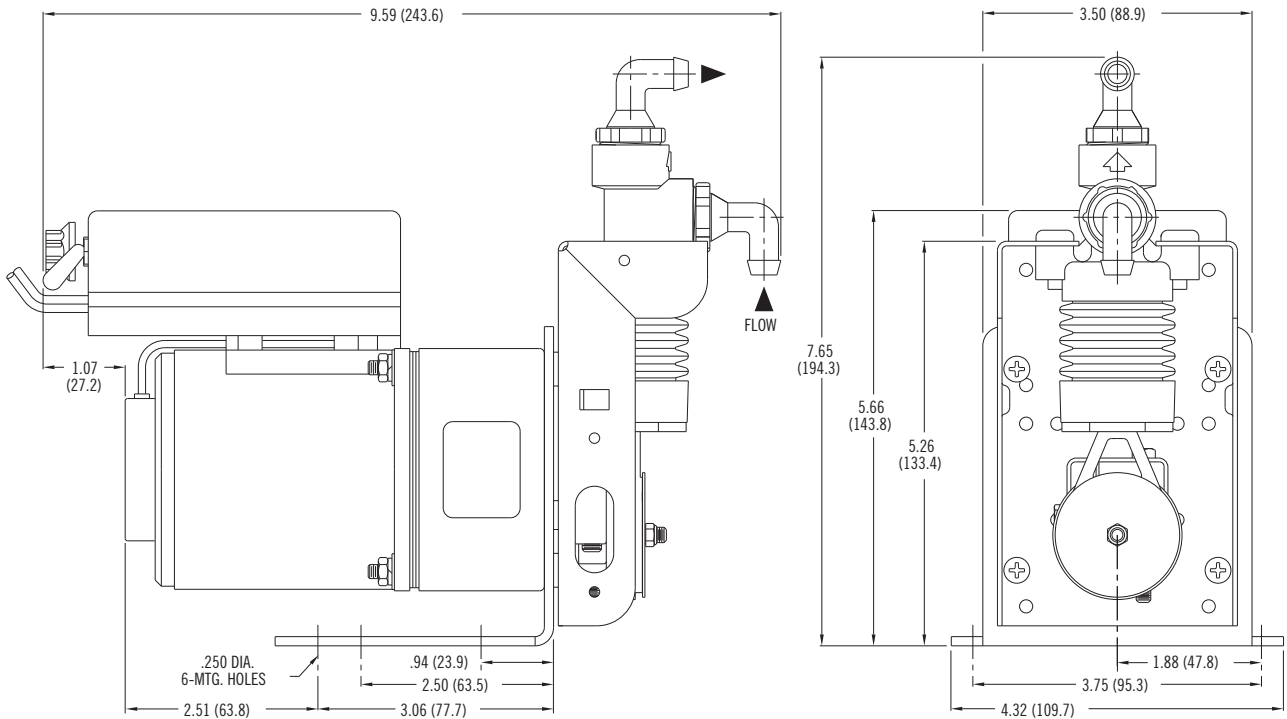

Dimensions in Inches
(Dimensions in Millimeters)

Part Selection Guide - Bellows Metering

Order notes: One "T" and one "X" code for each bellows module is required. (When ordering tandem pumps, the largest bellows module is nearest the gearmotor.)

Example: 13726-014 (1½" x 1½" two tandem standard model) with EPT/EPDM poppet valves and O-rings and 3/8" elbow connectors would be ordered as a 13726-014 X-112 T-008 X-112 T-008.

For flows of 1800 ml/min and above, ½" I.D. tubing connectors recommended.

*Use of 4mm connector is limited by flow rate; please contact factory with specifications.

**Cost added for connector.



T-001

T-CODES			
T-Code	For Elastomeric Tubing Size	Connector Type	Bellows Module Size
T-001	½" I.D. x ¼" O.D.	Barbed Compression	½"
T-002	¼" I.D. x ⅜" O.D.	Barbed Compression	½"
T-003	⅜" I.D.	Barbed	1", 1½" & 2½"
T-004	½" I.D.	Barbed	1", 1½" & 2½"
T-005	⅛" pipe thread	Female NPT	1", 1½" & 2½"
T-006**	⅛" I.D. x ¼" O.D.	Barbed Compression	1", 1½" & 2½"
T-007**	¼" I.D. X ⅜" O.D.	Barbed Compression	1", 1½" & 2½"
T-008	⅜" I.D.	Elbow Swivel, Barbed	1", 1½" & 2½"
T-009	½" I.D.	Elbow Swivel, Barbed	1", 1½" & 2½"
T-011	¼" I.D.	Elbow Swivel, Barbed	1", 1½" & 2½"
T-012*	4mm (5/32") I.D.	Elbow Swivel, Barbed	1", 1½" & 2½"
T-013*	4mm (5/32") I.D.	Elbow Swivel, Barbed	½"
T-014	¼" I.D.	Barbed	1", 1½" & 2½"



T-002



T-003



T-004



T-005



T-006



T-007



T-008



T-009



T-011



T-012



T-013



T-014

Poppet Valves and O-Rings (X-codes)

X-CODES			
Materials	½" Bellows	1" & 1½" Bellows	2½" Bellows
Butyl	—	X-111	X-121
*EPT/EPDM	X-002	X-112	X-122
Hydrin	X-003	X-113	X-123
*Viton®/ Fluoroelastomer	X-006	X-116	X-126
Silicone	X-008	X-118	X-128
Nitrile	—	X-119	X-129

*Indicates stocked elastomer. **Cost added for material.



½" Poppet Kit



1", 1½" and 2½" Poppet Kit

Duckbill Valves and O-Rings (X-codes)

X-CODES			
Materials	½" Bellows	1" & 1½" Bellows	2½" Bellows
Butyl	X-091	X-031	X-041
*EPT/EPDM	X-092	X-032	X-042
Hydrin	X-093	X-033	X-043
**Viton®/ Fluoroelastomer	X-096	X-036	X-046
Silicone	X-098	X-038	X-048
Nitrile	X-099	X-039	X-049

*Indicates stocked elastomer. **Cost added for material.



½" Duckbill Valve Kits



1", 1½" and 2½" Duckbill Valve Kits (Valve extension required only on suction port.)

GRI specializes in the adaptation of standard models to meet the ever-changing needs of the Original Equipment Market. Contact us if one of our standard models does not meet your specific requirements.

Motors

- **Speeds**
 Standard motor speeds are 39, 60, 90 and 165 RPM at 60 Hz. Gearmotors can be supplied in virtually any speed up to 165 RPM.
- **Voltages**
 Standard voltages are 115V, 50/60 Hz or 230V, 50/60 Hz. However, the following special voltages are also available: 12 and 24 VDC.
- **Designs**
 The standard motor is an open, shaded pole gearmotor. Motors are also available with brakes.
- **Options**
 Units without motors (pedestal models) are available on some models.

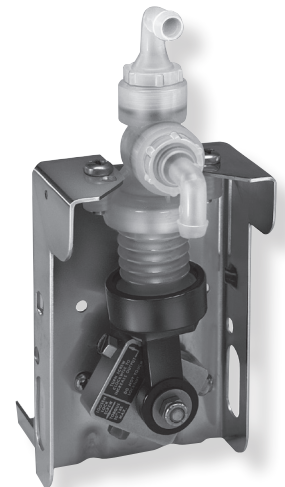

PEDESTAL MODEL



Valve Bodies

Standard valve body on the bellows pump is a 90° valve body. Vertical and T-head valve bodies can be substituted on all bellows sizes except the 1/2" bellows.



Poppet Valve

Standard poppet valve materials are available. Polypropylene material can be substituted.

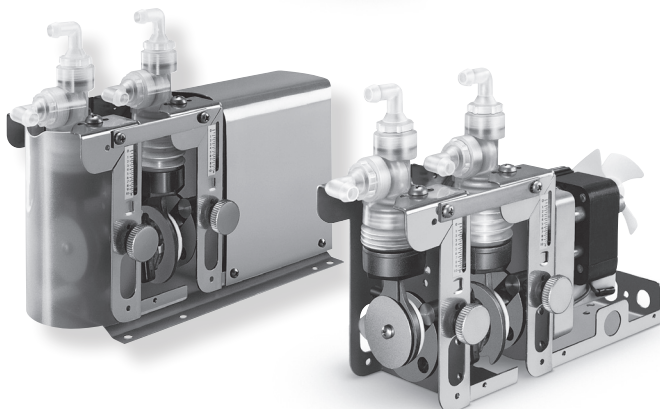

Pump Cover

Bellows pumps are available with or without a stainless steel cover, front shield, on/off switch, and cord and plug. Mounting brackets are also available with epoxy-coated rolled steel. However, a minimum quantity purchase is required.

Check and Foot Valves

Check and foot valves are used to maintain a pump's prime or to prevent backflow through a pump in applications with long suction lengths. Check valves can be positioned in-line on the suction or discharge side of the pump; foot valves on the suction side only. To order, refer to the chart on this page.

Elastomer	Single Check Valves		Dual Check Valves	Foot Valves	
	3/8" I.D. Tubing	1/2" I.D. Tubing	3/8" I.D. Tubing	3/8" I.D. Tubing	1/2" I.D. Tubing
EPT/EPDM	15099-002	15099-018	12171-004	15101-002	15101-018
Viton®/Fluoro-elastomer	15099-006	15099-022	—	15101-006	15101-022



Single Check Valve

Opening Pressure: 1 psi (spring loaded)

Materials in Contact with Solution:

- Body, valve seat, connectors, screen (149 Micron) - Polypropylene
- O-rings - EPT/EPDM, Viton®/Fluoro-elastomer
- Spring - Hastelloy® C

Options: 1/2" or 3/8" I.D. tubing connectors



Dual Check Valve

Opening Pressure: .2 psi (two poppets located in series)

Materials in Contact with Solution:

- Body, connectors - Polypropylene
- Poppet valves & O-rings — EPT/EPDM



Foot Valve

Opening Pressure: 1 psi (spring loaded)

Materials in Contact with Solution:

- Body, valve seat, connectors, screen (149 Micron) - Polypropylene
- O-rings - EPT/EPDM, Viton®/Fluoro-elastomer
- Spring - Hastelloy® C

Options: 1/2" or 3/8" I.D. tubing connectors

Anti-Siphon Spring Kits

Anti-siphon springs are available to springload poppet valves. Use of these springs produces more positive shutoff of poppet valves and permits use of the pump where there is a positive pressure on the suction side. Available for the 1", 1 1/2"

and 2 1/2" models. To order, select the proper spring material and O-ring by referring to the Chemical Resistance Section. The appropriate kit can then be chosen based on the blow-off pressure (PSI) required.



(Valve extension required only on suction port.)

Spring	O-Ring (Elastomer) Material			
	EPT/EPDM		Viton®/Fluoroelastomer	
	.5 PSI	5 PSI	.5 PSI	5 PSI
Monel	02501-112	02501-113	02501-124	02501-525
316 S.S.	02501-114	02501-115	02501-126	02501-127
Hastelloy® C	02501-116	02501-117	02501-128	02501-129

Kits include valve extension for suction port. Kits do not include poppet valve.

Bellows Module Kits

Bellows module kits include connecting rod assembly, bellows module, displacement cup, screws and O-rings.



2 1/2" Standard Kit



2 1/2" BEL O JUST® Kit



1 1/2" Standard Kit



1/2" BEL O JUST® Kit

Crank Kits

Standard crank kit includes lock nut, flat washer and crank assembly.

BEL O JUST® crank kit includes rod bushing, bearing, bearing bushing, drive arm, set screw, bushing, crank, control arm and retaining ring.



Standard Crank Kit

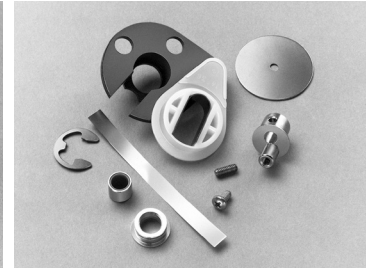

BEL O JUST® Crank Kit

Motor Kit

Motor kit includes motor, fan, mounting screws, felt pad and ground screw.



Motor Kit

Ordering Kits

To order, refer to Replacement Kit charts on following pages.

SINGLE BELLOWS METERING PUMPS - REPLACEMENT KITS

Model Number	Bellows Module Replacement Kits								Crank Assembly Replacement Kits		Motor Replacement Kits
	Butyl	EPT/EPDM	Hydrin	Hypalon®	Kel-F®	Viton®/Fluoro-elastomer	Silicone	Nitrile	Inner Module	Outer Module	
12800-007	02500-984	02500-649	—	—	—	02500-652	02500-653	—	—	02501-092	02501-091
12800-026	02500-984	02500-649	—	—	—	02500-652	02500-653	—	—	02501-092	02501-090
12950-003	02500-376	02500-284	—	—	02500-374	02500-373	02500-372	—	—	02500-853	02500-996
12950-004	02500-376	02500-284	—	—	02500-374	02500-373	02500-372	—	—	02500-853	02501-003
13300-007	02500-388	02500-274	—	—	02500-386	02500-385	02500-384	—	—	02500-852	02500-996
13300-008	02500-388	02500-274	—	—	02500-386	02500-385	02500-384	—	—	02500-852	02501-003
13300-009	02500-388	02500-274	—	—	02500-386	02500-385	02500-384	—	—	02500-852	02500-995
13300-010	02500-388	02500-274	—	—	02500-386	02500-385	02500-384	—	—	02500-852	02501-004
13300-045	02500-388	02500-274	—	—	02500-386	02500-385	02500-384	—	—	02500-852	02500-999
13300-046	02500-388	02500-274	—	—	02500-386	02500-385	02500-384	—	—	02500-852	02501-005
13300-047	02500-388	02500-274	—	—	02500-386	02500-385	02500-384	—	—	02500-852	02501-000
13300-048	02500-388	02500-274	—	—	02500-386	02500-385	02500-384	—	—	02500-852	02501-006
13325-001	02500-382	02500-279	—	—	02500-380	02500-379	02500-378	—	—	02500-852	02500-996
13325-002	02500-382	02500-279	—	—	02500-380	02500-379	02500-378	—	—	02500-852	02501-003
13325-003	02500-382	02500-279	—	—	02500-380	02500-379	02500-378	—	—	02500-852	02500-995
13325-004	02500-382	02500-279	—	—	02500-380	02500-379	02500-378	—	—	02500-852	02501-004
13325-005	02500-382	02500-279	—	—	02500-380	02500-379	02500-378	—	—	02500-852	02500-999
13325-006	02500-382	02500-279	—	—	02500-380	02500-379	02500-378	—	—	02500-852	02501-005
13325-031	02500-382	02500-279	—	—	02500-380	02500-379	02500-378	—	—	02500-852	02501-000
13325-032	02500-382	02500-279	—	—	02500-380	02500-379	02500-378	—	—	02500-852	02501-006
13960-022	—	02500-315	—	—	02500-391	02500-314	02500-390	—	—	02500-851	02500-996
13960-024	—	02500-315	—	—	02500-391	02500-314	02500-390	—	—	02500-851	02501-003
13960-027	—	02500-315	—	—	02500-391	02500-314	02500-390	—	—	02500-851	02501-000
13960-028	—	02500-315	—	—	02500-391	02500-314	02500-390	—	—	02500-851	02501-006
14250-005	02500-428	02500-429	—	—	02500-431	02500-432	02500-433	—	—	02501-033	02500-996
14250-006	02500-428	02500-429	—	—	02500-431	02500-432	02500-433	—	—	02501-033	02501-003
14250-007	02500-428	02500-429	—	—	02500-431	02500-432	02500-433	—	—	02501-033	02500-995
14250-008	02500-428	02500-429	—	—	02500-431	02500-432	02500-433	—	—	02501-033	02501-004
14250-014	02500-428	02500-429	—	—	02500-431	02500-432	02500-433	—	—	02501-033	02500-999
14250-015	02500-428	02500-429	—	—	02500-431	02500-432	02500-433	—	—	02501-033	02501-005
14250-016	02500-428	02500-429	—	—	02500-431	02500-432	02500-433	—	—	02501-033	02501-000
14250-017	02500-428	02500-429	—	—	02500-431	02500-432	02500-433	—	—	02501-033	02501-006
14251-001	02500-436	02500-437	—	—	02500-439	02500-440	02500-441	—	—	02501-033	02500-996
14251-002	02500-436	02500-437	—	—	02500-439	02500-440	02500-441	—	—	02501-033	02501-003
14251-003	02500-436	02500-437	—	—	02500-439	02500-440	02500-441	—	—	02501-033	02500-995
14251-004	02500-436	02500-437	—	—	02500-439	02500-440	02500-441	—	—	02501-033	02501-004
14251-005	02500-436	02500-437	—	—	02500-439	02500-440	02500-441	—	—	02501-033	02500-999
14251-006	02500-436	02500-437	—	—	02500-439	02500-440	02500-441	—	—	02501-033	02501-005
14251-007	02500-436	02500-437	—	—	02500-439	02500-440	02500-441	—	—	02501-033	02501-000
14251-008	02500-436	02500-437	—	—	02500-439	02500-440	02500-441	—	—	02501-033	02501-006
14280-006	—	02500-421	—	—	02500-423	02500-424	02500-425	02500-426	—	02501-035	02500-996
14280-007	—	02500-421	—	—	02500-423	02500-424	02500-425	02500-426	—	02501-035	02501-003
14280-009	—	02500-421	—	—	02500-423	02500-424	02500-425	02500-426	—	02501-035	02501-000
14280-014	—	02500-421	—	—	02500-423	02500-424	02500-425	02500-426	—	02501-035	02501-006
14282-001	02500-428	02500-429	—	—	02500-431	02500-432	02500-433	—	—	02501-033	—
14291-001	02500-388	02500-274	—	—	02500-386	02500-385	02500-384	—	—	02500-852	—
—	02500-627	02500-628	—	—	02500-630	02500-632	—	—	—	02501-033	02500-999
—	02500-627	02500-628	—	—	02500-630	02500-632	—	—	—	02501-033	02501-005
15090-001	02500-969	02501-647	—	—	02500-972	02500-973	02500-974	—	—	02501-093	02501-091
15090-002	02500-969	02501-647	—	—	02500-972	02500-973	02500-974	—	—	02501-093	02501-090
15090-003	—	02501-646	—	—	—	02500-965	—	—	—	02501-093	02501-091
15090-004	—	02501-646	—	—	—	02500-965	—	—	—	02501-093	02501-090

SINGLE BELLOWS METERING PUMPS - REPLACEMENT KITS

Model Number	Bellows Module Replacement Kits								Crank Assembly Replacement Kits		Motor Replacement Kits
	Butyl	EPT/EPDM	Hydrin	Hypalon®	Kel-F®	Viton®/Fluoro-elastomer	Silicone	Nitrile	Inner Module	Outer Module	
15950-001	—	02501-255	—	—	—	02501-257	—	—	—	02500-852	—
15955-001	—	02501-255	—	—	—	02501-257	—	—	—	02500-852	—
15955-002	—	02501-255	—	—	—	02501-257	—	—	—	02500-852	—
15956-001	—	02501-323	—	—	—	02501-324	—	—	—	02500-879	—
15956-002	—	02501-323	—	—	—	02501-324	—	—	—	02500-879	—

SIDE-BY-SIDE BELLOWS PUMPS - REPLACEMENT KITS

13191-043	02500-382	02500-279	—	—	02500-380	02500-379	02500-378	—	—	02500-852	02501-027
13191-044	02500-382	02500-279	—	—	02500-380	02500-379	02500-378	—	—	02500-852	02501-031
13193-001	02500-376	02500-284	—	—	02500-374	02500-373	02500-372	—	02500-853	—	02501-027
13193-002	02500-376	02500-284	—	—	02500-374	02500-373	02500-372	—	02500-853	—	02501-031

TWO TANDEM BELLOWS PUMPS - REPLACEMENT KITS

13701-019	—	02500-274	—	—	—	02500-385	—	—	02500-855	02500-852	02500-999
13701-020	—	02500-274	—	—	—	02500-385	—	—	02500-855	02500-852	02501-005
13701-021	—	02500-274	—	—	—	02500-385	—	—	02500-855	02500-852	02500-995
13701-022	—	02500-274	—	—	—	02500-385	—	—	02500-855	02500-852	02501-004
13726-014	02500-382	02500-279	—	—	02500-380	02500-379	02500-378	—	02500-855	02500-852	02500-999
13726-015	02500-382	02500-279	—	—	02500-380	02500-379	02500-378	—	02500-855	02500-852	02501-005
13726-016	—	02500-279	—	—	—	02500-379	—	—	02500-855	02500-852	02500-995
13726-017	—	02500-279	—	—	—	02500-379	—	—	02500-855	02500-852	02501-004
14324-027	—	02500-429	—	—	—	02500-432	—	—	02501-034	02501-033	02500-999
14324-028	—	02500-429	—	—	—	02500-432	—	—	02501-034	02501-033	02501-005
14324-029	—	02500-429	—	—	—	02500-432	—	—	02501-034	02501-033	02500-995
14324-030	—	02500-429	—	—	—	02500-432	—	—	02501-034	02501-033	02501-004
15904-001	02500-436	02500-437	—	—	02500-439	02500-440	02500-441	—	02501-034	02501-033	02500-999
15904-002	02500-436	02500-437	—	—	02500-439	02500-440	02500-441	—	02501-034	02501-033	02501-005
15904-003	02500-436	02500-437	—	—	02500-439	02500-440	02500-441	—	02501-034	02501-033	02500-995
15904-004	02500-436	02500-437	—	—	02500-439	02500-440	02500-441	—	02501-034	02501-033	02501-004

THREE TANDEM BELLOWS PUMPS - REPLACEMENT KITS

13700-009	02500-382	02500-279	—	—	02500-380	02500-379	02500-378	—	02500-855	02500-852	02500-999
13700-010	—	02500-279	—	—	—	02500-379	—	—	02500-855	02500-852	02501-005
13700-011	—	02500-279	—	—	—	02500-379	—	—	02500-855	02500-852	02500-995
13700-012	—	02500-279	—	—	—	02500-379	—	—	02500-855	02500-852	02501-004
13716-009	02500-382	02500-279	—	—	02500-380	02500-379	02500-378	—	02500-855	02500-852	02500-999
13716-010	02500-382	02500-279	—	—	02500-380	02500-379	02500-378	—	02500-855	02500-852	02501-005
13716-012	—	02500-279	—	—	—	02500-379	—	—	02500-855	02500-852	02500-995
13716-013	—	02500-279	—	—	—	02500-379	—	—	02500-855	02500-852	02501-004
14252-005	—	02500-429	—	—	—	02500-432	—	—	02501-034	02501-033	02500-999
14252-006	—	02500-429	—	—	—	02500-432	—	—	02501-034	02501-033	02501-005
14252-007	—	02500-429	—	—	—	02500-432	—	—	02501-034	02501-033	02500-995
14252-008	—	02500-429	—	—	—	02500-432	—	—	02501-034	02501-033	02501-004
15905-001	02500-436	02500-437	—	—	02500-439	02500-440	02500-441	—	02501-034	02501-033	02500-999
15905-002	02500-436	02500-437	—	—	02500-439	02500-440	02500-441	—	02501-034	02501-033	02501-005
15905-003	—	02500-437	—	—	—	02500-440	—	—	02501-034	02501-033	02500-995
15905-004	—	02500-437	—	—	—	02500-440	—	—	02501-034	02501-033	02501-004



Poppet Valve Kit

Poppet valve kit includes two poppet valves and two O-rings.



POPPET VALVE AND O-RING KITS								
Bellows Size	Materials							
	Butyl	EPT/EPDM	Hydrin	Hypalon®	Kel-F®	Viton®/Fluoro-elastomer	Silicone	Nitrile
½"	—	02500-318 (X-002)	—	—	02500-349 (X-004)	02500-317 (X-006)	02500-350 (X-008)	—
1"	02500-604 (X-111)	02500-605 (X-112)	—	—	02500-607 (X-114)	02500-609 (X-116)	02500-610 (X-118)	—
1½"	02500-604 (X-111)	02500-605 (X-112)	—	—	02500-607 (X-114)	02500-609 (X-116)	02500-610 (X-118)	—
2½"	02500-604 (X-121)	02500-605 (X-122)	—	—	02500-607 (X-124)	02500-609 (X-126)	02501-486 (X-128)	—

Duckbill Valve Kit

Duckbill valve kit includes two duckbill valves, two seal washers, one valve extension and one O-ring.



DUCKBILL VALVE AND O-RING KITS								
Bellows Size	Materials							
	Butyl	EPT/EPDM	Hydrin	Hypalon®	Kel-F®	Viton®/Fluoro-elastomer	Silicone	Nitrile
½"	—	02500-597 (X-092)	—	—	02500-599 (X-094)	02500-601 (X-096)	—	—
1"	—	02500-322 (X-032)	—	—	02500-355 (X-034)	02500-319 (X-036)	02500-324 (X-038)	—
1½"	—	02500-322 (X-032)	—	—	02500-355 (X-034)	02500-319 (X-036)	02500-324 (X-038)	—
2½"	—	02500-322 (X-042)	—	—	02500-355 (X-044)	02500-319 (X-046)	02500-324 (X-048)	—

TUBING CONNECTOR KITS

T-Code	Kit Part Number
T-001	02500-312
T-002	02500-635
T-003	02500-352
T-004	02500-353
T-005	02500-258
T-006	02500-259
T-007	02500-260
T-008	02500-261
T-009	02500-354
T-011	02501-337
T-012	02501-246
T-013	02501-541
T-014	02501-673

Tubing Connector Kit

Tubing connector kit includes two connectors and two connector nuts.



Blank Page

