

INTEGRITY^{series}™

Tuned for performance, stability and longevity.



GRI[®]
PUMPS
A GORMAN-RUPP COMPANY

The Pump People[®]



Welcome to Gorman-Rupp Industries, home of “The Pump People!”

Thank you for considering Gorman-Rupp Industries and our Integrity Series Circulation Pumps.

Since 1953, GRI has served OEMs worldwide with custom-engineered pumps. When an off-the-shelf pump will not satisfy your pumping requirements, count on GRI Pumps to design a pump specific to your OEM application.

Quality begins at home. Located 10 miles south of Gorman-Rupp’s corporate headquarters, the Gorman-Rupp Industries (GRI) division continues the legacy and unmatched quality that Gorman-Rupp has been known for since its founding by J.C. Gorman and Herb Rupp in 1933.

Made in the U.S.A. GRI designs and manufactures all products in our Bellville, Ohio, 98,000 square foot facility. Our vertical manufacturing combined with 92% of our suppliers residing in the U.S. allows GRI to proudly claim, “Made in the U.S.A!”

Our Pump Teams welcome the opportunity to discuss and answer any questions regarding your fluid pump opportunity. You can contact GRI through a phone call, email, or our website.

Call: 419-886-3001 (We answer the phone!)

Email: grisales@gripumps.com

Online: www.GRIpumps.com/contact

Again, thank you for considering GRI Pumps - we look forward to serving you!



MARKETS AND APPLICATIONS

GRI collaborates with OEM engineers who are unable to fulfill their unique pump specifications with an off-the-shelf solution and require a custom-engineered pump specific to their application.



Alternative Energy

Prepared for the technological challenges with energy efficient pumping solutions.



Appliances

Long lasting, highly efficient, chemically resistant fluid circulation and metering pumps.



Chillers & Coolers

Leak-free, long-life, quiet operation and low power consumption.



Food & Beverage

Efficient, quiet, long-lasting, compact, NSF and FDA compliant pumps and components.



General Industrial

Designed to handle harsh fluids and chemicals in demanding high-pressure applications.



HVAC

Compact, quiet, leak-free, and energy efficient designs.



Laboratory & Analytical Instrumentation

Accurate, leak-free, chemically resistant OEM pumps.



Medical

Custom OEM pumps with accurate, chemically resistant, contamination-free designs.



Printing & Image Reproduction

Long lasting, leak-free, and accurate metering capabilities.



Server & Electronics Cooling

Leak-free, long-lasting, efficient pumps trusted around the world to safely pump fluid in critical applications.



Transportation

Compact, lightweight, long-lasting, hydraulically efficient OEM pumps.

INTEGRITY^{series}™

Tuned for performance, stability and longevity.

Designed for the circulation and transfer of fluids, GRI's Integrity Series Pumps offer a flexible, safe and robust solution to moving fluid in critical high-tech OEM applications.

Equipped with an integrated brushless DC variable speed motor, with ranges of 12 to 48 volts, these seal-less, motor integrated centrifugal pumps incorporate the components into a compact, lightweight design. Fewer parts promote long life, quiet operation, and low power consumption.

Unlike its competition, GRI manufactures the pump's brushless DC motors, along with the majority of the components, in-house. Our vertical integration provides the ability to customize a pump's motor to an OEM's specific flow and pressure performance requirements.

Integrity Series Pumps are designed and manufactured specifically for OEM customization. If you don't immediately find a pump that meets your exact requirements, our dedicated Pump Team is ready to work with you in developing a solution specific to your application.



INTG1 Brushless-DC Magnetic Drive

12-36 VDC
 Maximum System Pressure: 50 PSI
 Maximum Flow: 3.0 GPM; 12.0 LPM
 Maximum Head: 22.0 feet; 10.0 PSI



INTG3 Brushless-DC Magnetic Drive

12-24 VDC
 Maximum System Pressure: 75 PSI
 Maximum Flow: 8.85 GPM; 33.5 LPM
 Maximum Head: 37.0 FT; 16.00 PSI



INTG5 Brushless-DC Magnetic Drive

12-24, 36, 48 VDC
 Maximum System Pressure: 75 PSI
 Maximum Flow: 10.0 GPM; 37.9 LPM
 Maximum Head: 80.0 feet; 35.0 PSI



INTG7 Brushless-DC Magnetic Drive

12-48 VDC
 Maximum System Pressure: 75 PSI
 Maximum Flow: 22.0 GPM; 83.0 LPM
 Maximum Head: 80.0 feet; 35.0 PSI



INTG8 Brushless-DC Magnetic Drive

12-48 VDC
 Maximum System Pressure: 75 PSI
 Maximum Flow: 39.0 GPM; 145.0 LPM
 Maximum Head: 70.0 feet; 30.0 PSI

Integrated Magnetic Drive Circulation Pumps Series Comparison

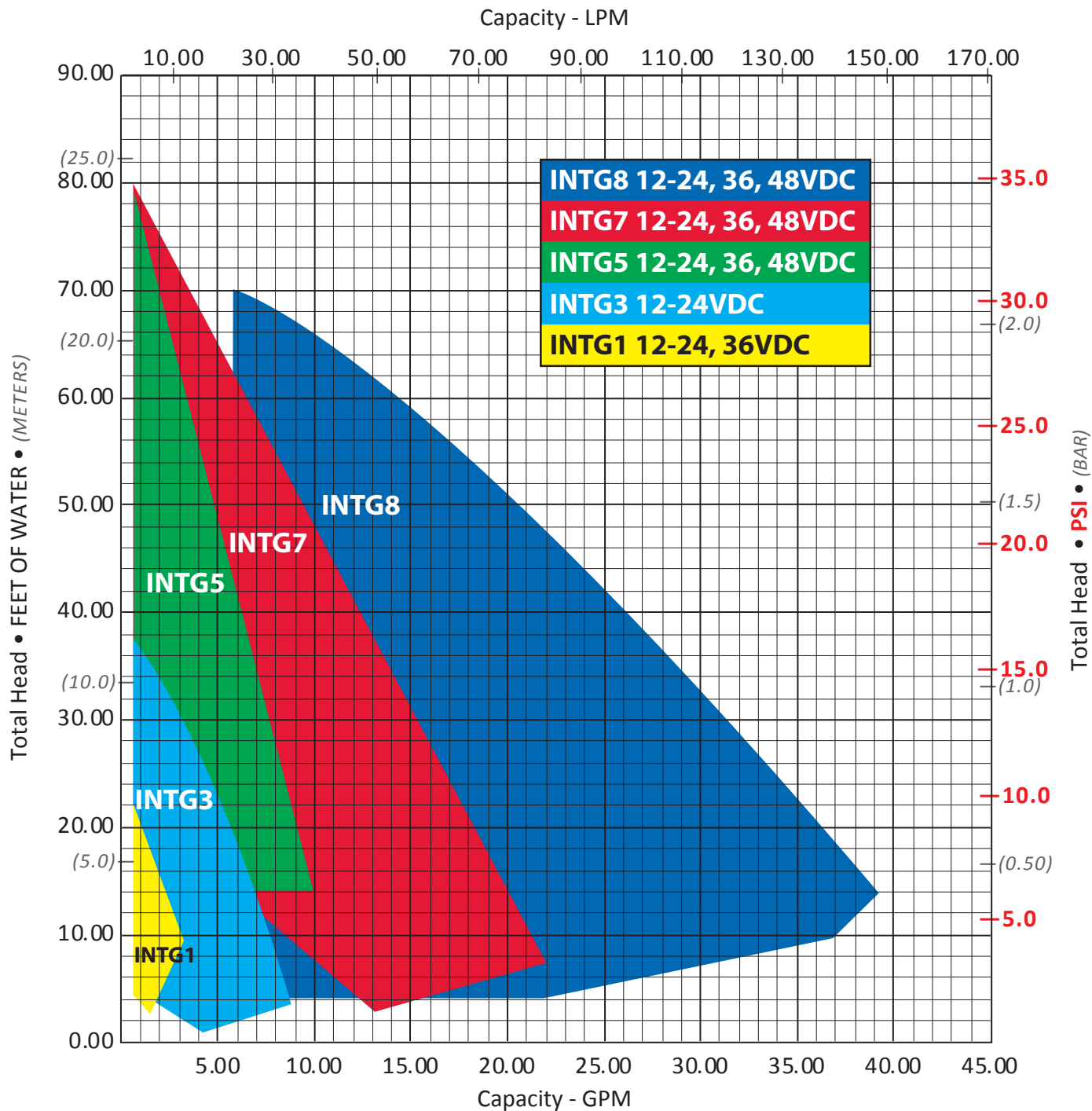

To protect the control board, each Integrity Series pump will be issued with a Maximum Power limit (Watts).
 To stay within this limit, the recommended fuse size (Amps) will be based on the voltage supplied. (Watts = Voltage X Amps)

INTG1 Series • Maximum flow per voltage						
Voltage	Flow (GPM)	Flow (L)	Ttl. Hd. (Ft)	Ttl. Hd. (PSI)	Ttl. Hd. (BAR)	Ttl. Hd. (M)
36vdc	3.20	12.10	9.49	4.11	0.28	2.89
24vdc	2.52	9.55	6.26	2.71	0.19	1.91
21vdc	2.36	8.92	5.76	2.50	0.17	1.76
18vdc	2.12	8.02	4.73	2.05	0.14	1.44
15vdc	1.84	6.98	3.58	1.55	0.11	1.09
12vdc	1.58	5.98	2.65	1.15	0.08	0.81

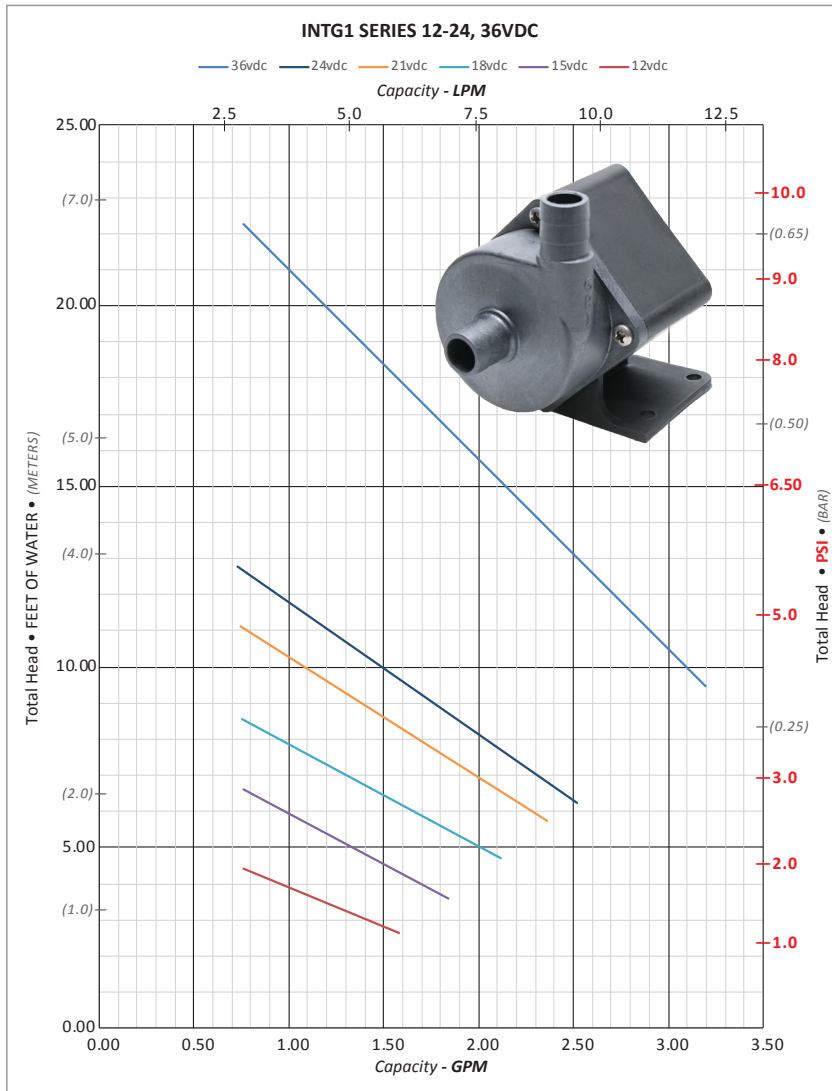

Note: Testing performed in a controlled laboratory environment. Actual performance may vary (+) or (-) 10% from the information shown.
Do Not Run Pumps Dry. Pumps must be in a continuous flooded suction environment.

Specifications

Maximum System Pressure: 50 psi

Approximate Weight: .8 LBS (362.9 grams)

Ports: 1/2" MHB, 3/8" MPT
 OEM Customization Available

Materials In Contact With Solution

Body: PPS	Impeller Shaft: Stainless Steel or Ceramic
Impeller: PPS	Housing: PPS
Static O-Ring: EPDM, FKM	

Motor Specifications

Motor: Integrated, Brushless DC

Supply Voltage: 12-36 VDC

Electronics Maximum Power: 18 Watts

To protect the control board, each Integrity Series pump will be issued with a Maximum Power limit (Watts). To stay within this limit, the recommended fuse size (Amps) will be based on the voltage supplied. (Watts = Voltage X Amps)

Control Options

- **Direct Supply Voltage:** Speed of the pump determined by the voltage supplied
- **Analog:** 0-5v DC signal
- **Tachometer:** Feedback option available

Maximum Fluid Rating Chart

Controller Position	Maximum Fluid Temp Rating
Separate from pump	Not Applicable
Within pump's housing	149°F (65°C)

Various factors influence the recommended maximum temperature rating. These factors play a role in determining the pump's life and applied warranties. In some applications, a higher maximum fluid temperature rating may be warranted.

Factors influencing maximum temperature rating include, but are not limited to:

- Starting temperature of fluid in system
- Ambient temperature
- Required performance, application's specifications
- Run time

Optional Agency Approvals

- **UL778:** Motor-Operated Water Pumps
- **NSF 61:** Potable Water
- **NSF 169:** Food Grade

RoHS/REACH

Many GRI pumps are RoHS & REACH compliant. For declarations by specific model numbers, please contact GRI.

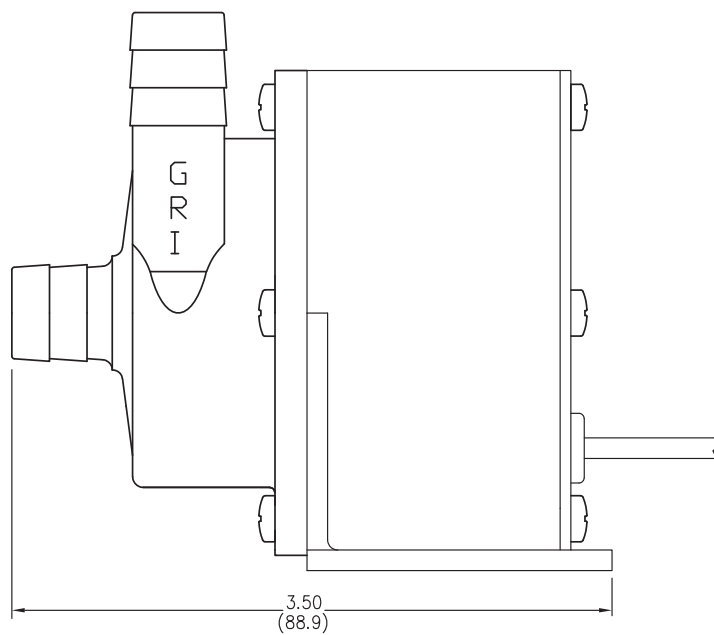
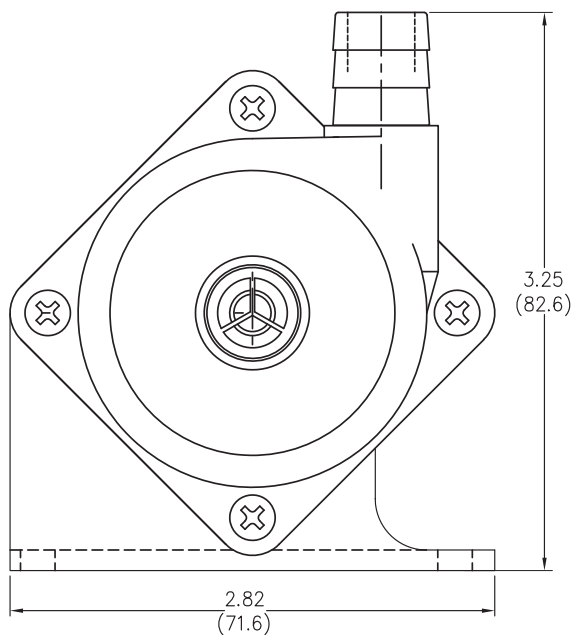

INTG1 Series Typical Dimensional Drawing.
 Many other OEM port options and configurations are available. Please contact GRI to discuss.

Port Options

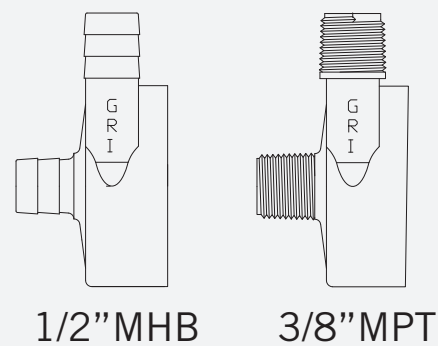

Integrity Series Pumps are designed and manufactured specifically for OEM customization. If you don't immediately find a pump that meets your exact requirements, our dedicated Pump Team is ready to work with you in developing a solution specific to your application.

INTG1 SERIES MODELS				Ports Inches	Max Flow GPM (LPM)	Max Head Ft. (PSI) (m)	Voltage
EPDM O-Ring		FKM O-Ring					
2 wire: (+), (-)	3 wire:(+), (-), Speed Control	2 wire: (+), (-)	3 wire: (+), (-), Speed Control				
INTG1S-280	INTG1S-380	INTG1S-281	INTG1S-381	1/2" MHB	2.50 (9.50)	12.80 (5.5) (3.90)	12-24
INTG1S-284	INTG1S-384	INTG1S-285	INTG1S-385	3/8" MPT			

Connectors: MHB = Male Hose Barb; MPT = Male Pipe Thread | **O-Ring Material:** EPDM = Ethylene Propylene Diene Monomer, FKM = Fluoroelastomer.

Max Flow Per INTG3 Model Series							
Series	Voltage	Flow (GPM)	Flow (L)	Ttl. Hd. (Ft)	Ttl. Hd. (PSI)	Ttl. Hd. (BAR)	Ttl. Hd. (M)
INTG3-550 Series	21 VDC	8.85	33.50	2.36	1.02	0.07	0.72
INTG3-560 Series	24 VDC	6.70	25.40	14.87	6.45	0.44	4.53
INTG3 AC Series	115/230 VAC	8.00	30.5	9.67	4.2	.29	2.95

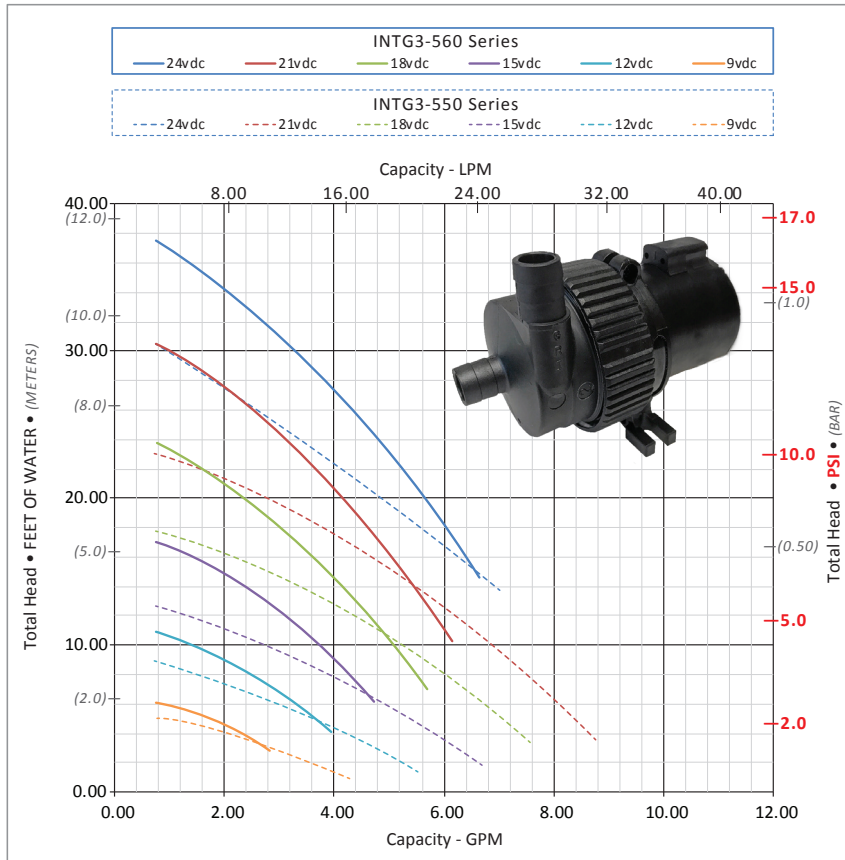

Note: Testing performed in a controlled laboratory environment. Actual performance may vary (+) or (-) 10% from the information shown.
Do Not Run Pumps Dry. Pumps must be in a continuous flooded suction environment.

Specifications
Maximum System Pressure: 75 psi
Approximate Weight: .8 LBS (362.9 grams)
Ports: 1/2", 3/4" MHB, 3/8" MPT / OEM Customization Available

Materials In Contact With Solution		
Body: PPS	Housing: PPS	Static O-Ring: EPDM, FKM
Impeller: PPS	Pump Shaft: Ceramic	

Motor Specifications	
Motor: Integrated, Brushless DC	Control Options
Supply Voltage:	<ul style="list-style-type: none"> • Direct Supply Voltage: Speed of the pump determined by the voltage supplied • Analog: 0-5v DC signal • Digital: PWM • Tachometer: Feedback option available
<ul style="list-style-type: none"> • 12-24 VDC • 115, 230 VAC (auto sensing technology), Optional with OEM quantities. 	
Electronics Maximum Power: 60 Watts To protect the control board, each Integrity Series pump will be issued with a Maximum Power limit (Watts). To stay within this limit, the recommended fuse size (Amps) will be based on the voltage supplied. (Watts = Voltage X Amps)	

Maximum Fluid Rating Chart	
Controller Position	Maximum Fluid Temp Rating
Separate from pump	225°F (107°C)
Within pump's housing	149°F (65°C)

Various factors influence the recommended maximum temperature rating. These factors play a role in determining the pump's life and applied warranties. In some applications, a higher maximum fluid temperature rating may be warranted.

- Factors influencing maximum temperature rating include, but are not limited to:
- Starting temperature of fluid in system
 - Ambient temperature
 - Required performance, application's specifications
 - Run time

Optional Agency Approvals	RoHS/REACH
UL778: Motor-Operated Water Pumps NSF61: Potable Water NSF372: Lead Content	Many GRI pumps are RoHS & REACH compliant. For declarations by specific model numbers, please contact GRI.

IP (Ingress Protection)
IP66: No ingress of dust, protection against powerful water jets.
IP67: No ingress of dust, protection against temporary water immersion.
IP68: No ingress of dust, protection against continuous water immersion.

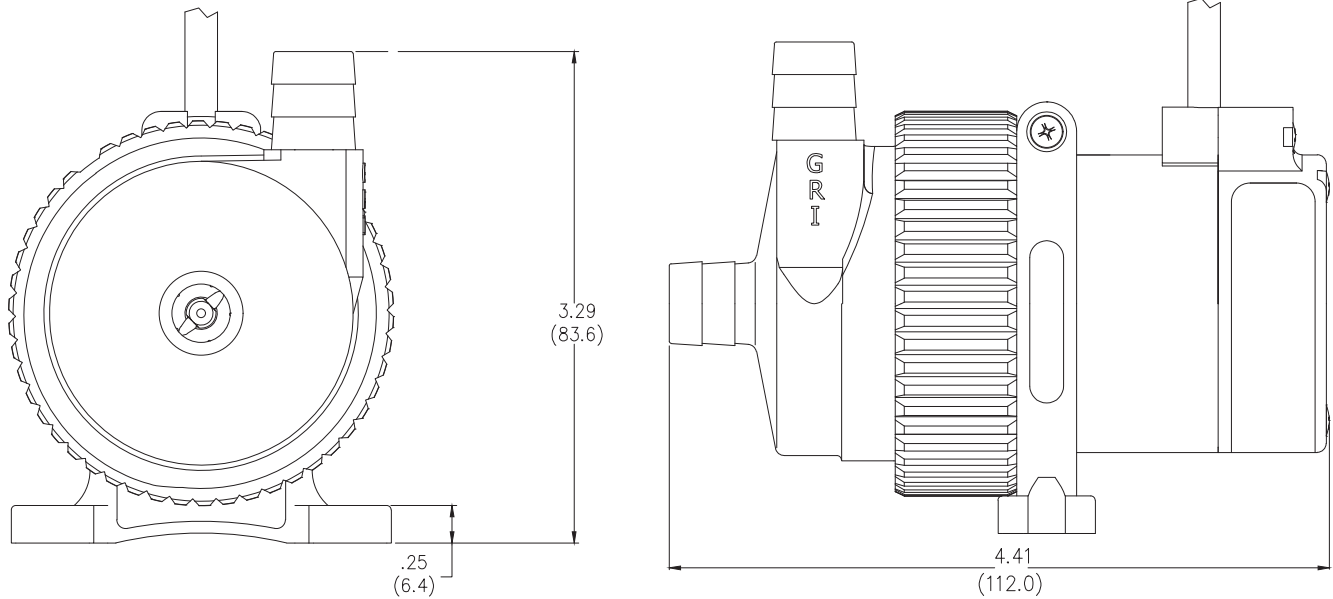

INTG3 Series Typical Dimensional Drawing. Many other OEM port options and configurations are available. Please contact GRI to discuss.

Base Model Options

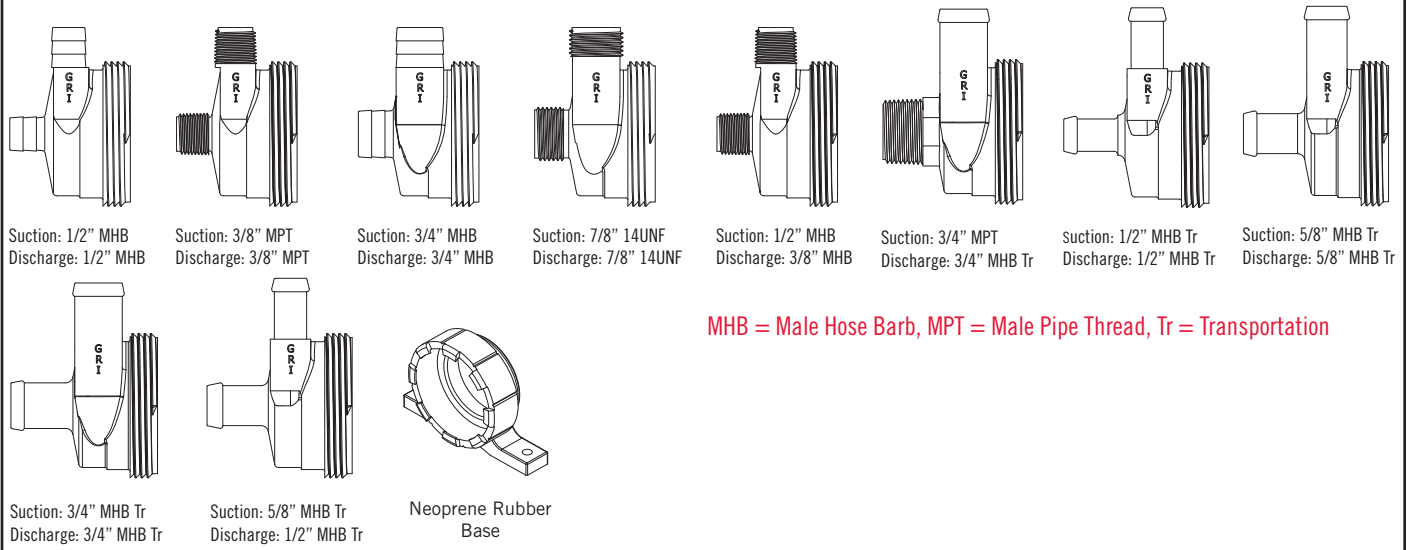

Integrity Series Pumps are designed and manufactured specifically for OEM customization. If you don't immediately find a pump that meets your exact requirements, our dedicated Pump Team is ready to work with you in developing a solution specific to your application.

INTG3 SERIES MODELS				Voltage	Max Flow GPM (LPM)	Max Head Ft. (PSI) (m)	Ports Inches
EPDM O-Ring		FKM O-Ring					
2 wire: DC (+), (-) AC (Line), (Neutral)	3 wire: (+), (-), Speed Control	2 wire: DC (+), (-) AC (Line), (Neutral)	3 wire: (+), (-), Speed Control				
INTG3-550	INTG3-552	INTG3-551	INTG3-553	12-24 VDC	8.85 (33.5)	32.00 (13.9) (17.7)	3/4 MHB
INTG3-560	INTG3-562	INTG3-561	INTG3-563		6.70 (25.4)	37.00 (16.0) (11.3)	1/2 MHB
INTG3-564	INTG3-566	INTG3-565	INTG3-567				3/8 MPT
INTG3-860 AC	—	INTG3-861 AC	—	115 VAC 230 VAC	8.00 (30.5)	45.00 (19.5) (13.7)	1/2 MHB

Connectors: MHB = Male Hose Barb; MPT = Male Pipe Thread | O-Ring Material: EPDM = Ethylene Propylene Diene Monomer, FKM = Fluoroelastomer.

INTG5 Series • Maximum flow per voltage						
Voltage	Flow (GPM)	Flow (L)	Ttl. Hd. (Ft)	Ttl. Hd. (PSI)	Ttl. Hd. (BAR)	Ttl. Hd. (M)
24 36 48vdc	10.00	37.85	14.41	6.25	0.43	4.39
21vdc	9.97	37.73	14.48	6.28	0.43	4.41
18vdc	8.80	33.31	13.93	6.04	0.42	4.25
15vdc	7.87	29.79	9.63	4.18	0.29	2.94
12vdc	4.13	15.63	16.33	7.08	0.49	4.98

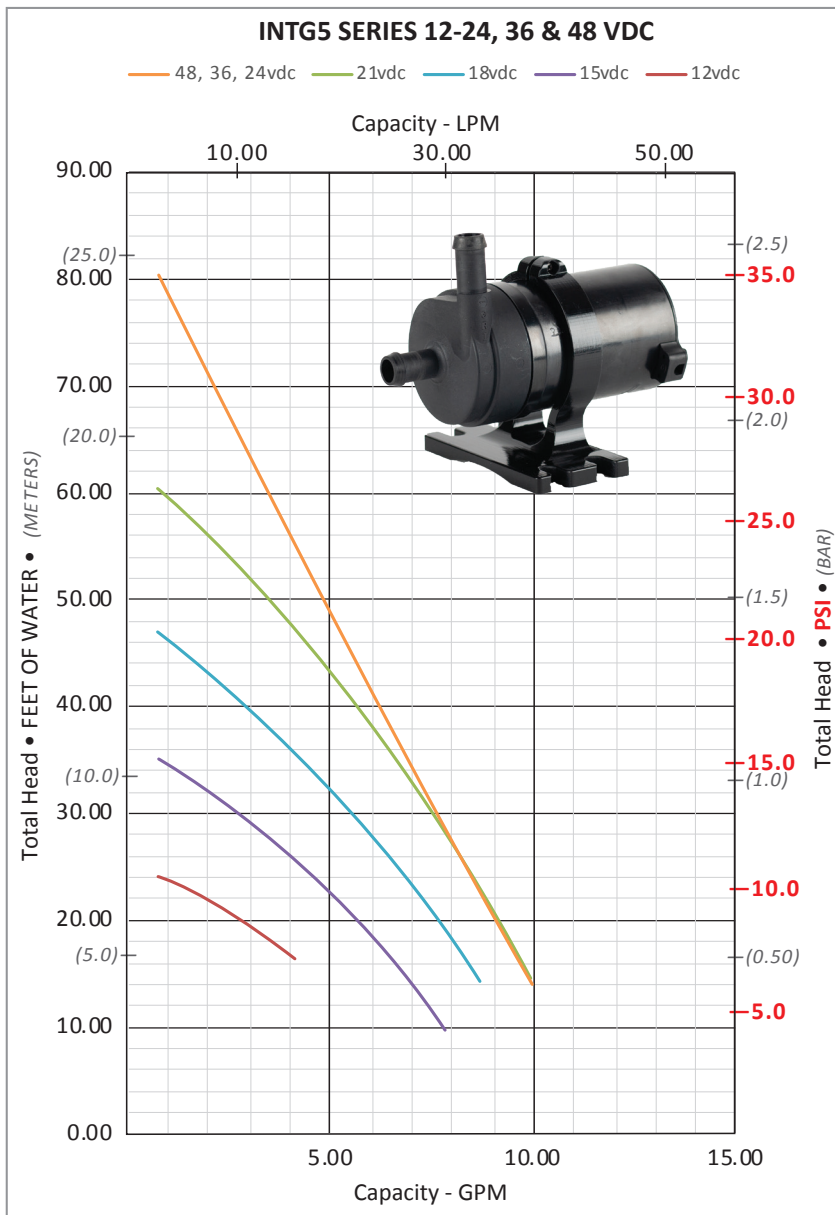

Note: Testing performed in a controlled laboratory environment. Actual performance may vary (+) or (-) 10% from the information shown.

Do Not Run Pumps Dry. Pumps must be in a continuous flooded suction environment.

Specifications
Maximum System Pressure: 75 psi
Approximate Weight (w/ external box): 3.2 LBS (1451.5 grams)
Ports: 1/2" MHBT, 3/4" MHB, 3/4" MPT, 7/8"-14 UNF OEM Customization Available

Motor specifications		
Motor: Integrated, Brushless DC	Control Options	
Supply Voltage: 12-48 VDC		
Electronics Maximum Power: 250 Watts	<ul style="list-style-type: none"> • Direct Supply Voltage: Speed of the pump determined by the voltage supplied • Analog: 0-5v DC Signal • Digital: PWM • CAN-Bus: Option available • Tachometer: Feedback option available 	
To protect the control board, each Integrity Series pump will be issued with a Maximum Power limit (Watts). To stay within this limit, the recommended fuse size (Amps) will be based on the voltage supplied. (Watts = Voltage X Amps)		

Materials in contact with solution	
Body: PPS	Housing: PPS
Impeller: PPS	Pump Shaft: Ceramic

Maximum Fluid Rating Chart	
Controller Position	Maximum Fluid Temp Rating
Separate from pump	225°F (107°C)
Within pump's housing	149°F (65°C)

Various factors influence the recommended maximum temperature rating. These factors play a role in determining the pump's life and applied warranties. In some applications, a higher maximum fluid temperature rating may be warranted.

Factors influencing maximum temperature rating include, but are not limited to:

- Starting temperature of fluid in system
- Ambient temperature
- Required performance, application's specifications
- Run time

Optional Agency Approvals
Contact GRI
RoHS/REACH
Many GRI pumps are RoHS & REACH compliant. For declarations by specific model numbers, please contact GRI.

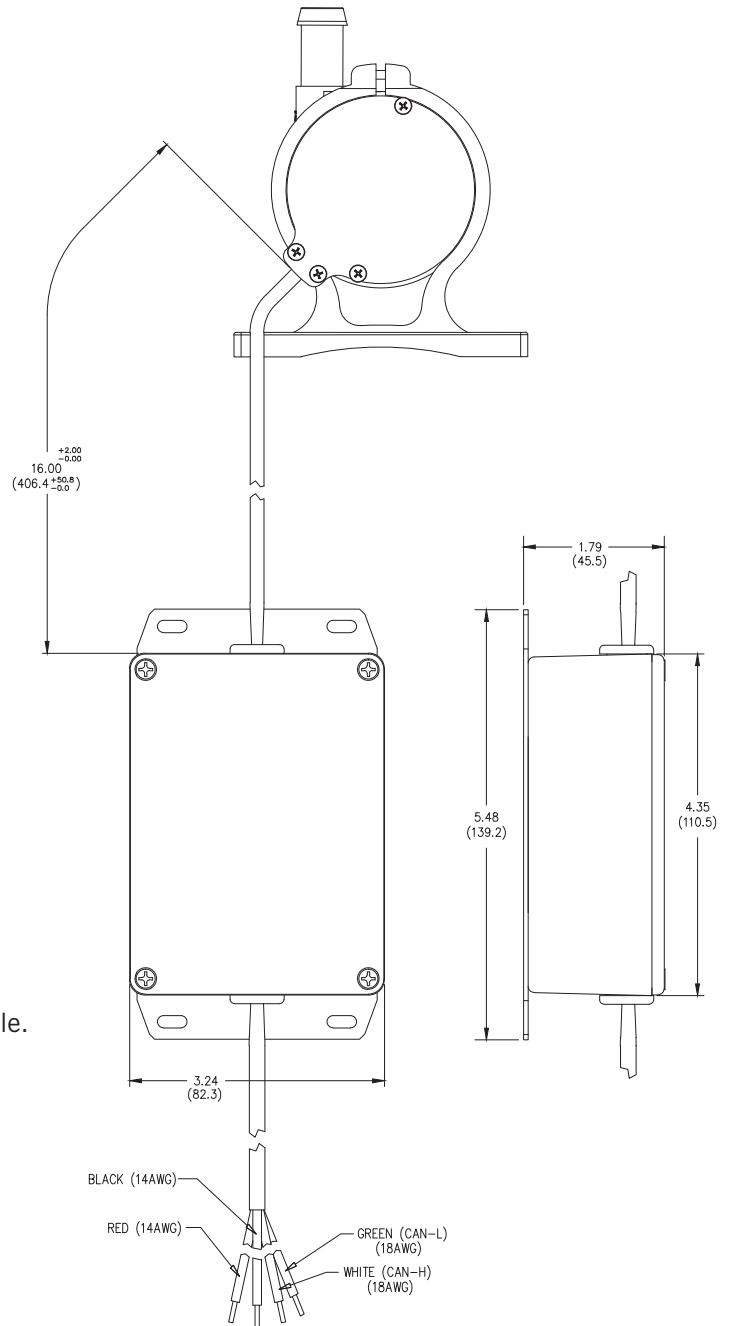
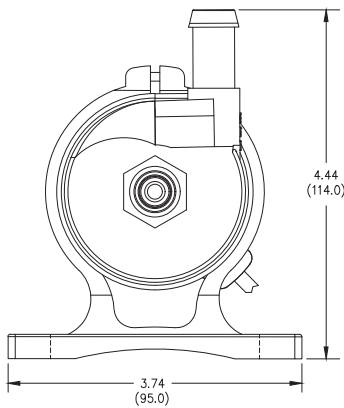
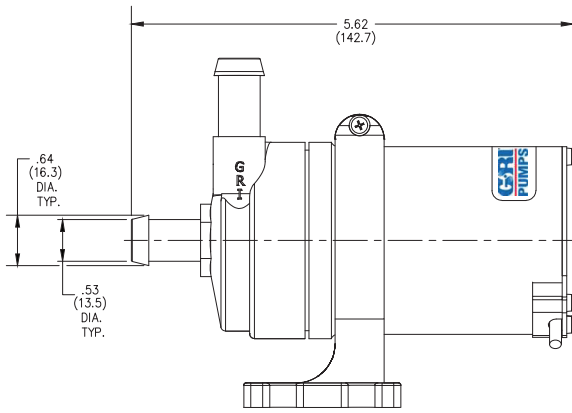

INTG5 Series Typical Dimensional Drawing.
 Many other OEM port options and configurations are available.
 Please contact GRI to discuss.

Port Options

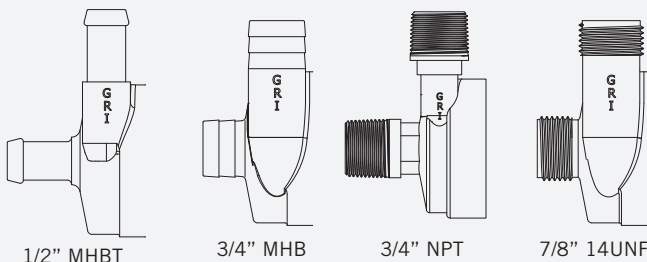

Integrity Series Pumps are designed and manufactured specifically for OEM customization. If you don't immediately find a pump that meets your exact requirements, our dedicated Pump Team is ready to work with you in developing a solution specific to your application.

INTG7 Series • Maximum flow per voltage						
Voltage	Flow (GPM)	Flow (L)	Ttl. Hd. (Ft)	Ttl. Hd. (PSI)	Ttl. Hd. (BAR)	Ttl. Hd. (M)
48vdc	21.99	83.25	7.52	3.26	0.22	2.29
36vdc	18.98	71.85	19.80	8.58	0.59	6.04
24vdc	22.08	83.59	7.25	3.14	2.21	5.50
21vdc	19.81	75.00	5.76	2.50	1.76	4.14
18vdc	17.73	67.13	4.73	2.05	1.44	2.94
15vdc	15.58	58.96	3.55	1.54	1.08	2.01
12vdc	13.16	49.83	2.49	1.08	0.76	1.24

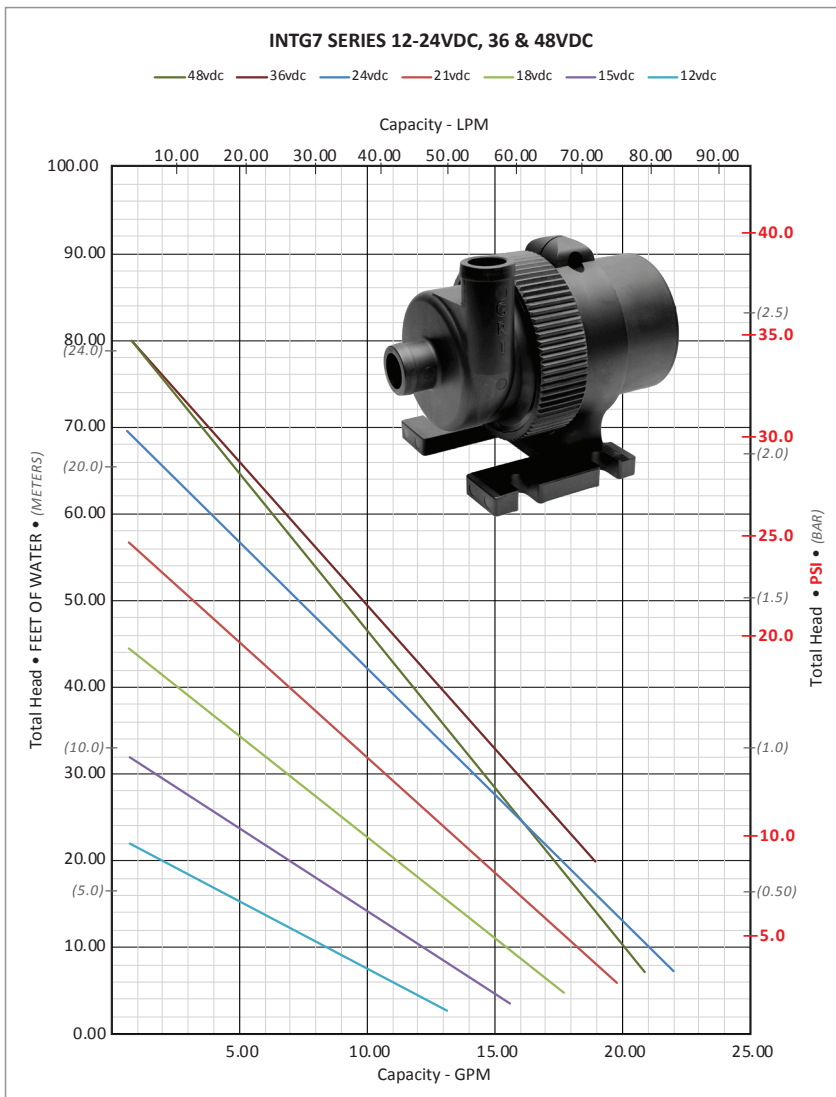

Note: Testing performed in a controlled laboratory environment. Actual performance may vary (+) or (-) 10% from the information shown.

Do Not Run Pumps Dry. Pumps must be in a continuous flooded suction environment.

Specifications

Maximum System Pressure: 75 psi

Approximate Weight (w/ external box): 4.3 lbs (1950.45 grams)

Ports: 1" MHB

Materials In Contact With Solution

Body: PPS	Housing: PPS	Static O-Ring: EPDM, FKM
Impeller: PPS	Pump Shaft: Ceramic	

Motor Specifications

Motor: Integrated, Brushless DC

Supply Voltage: 12-48 VDC

Electronics Maximum Power: 300 Watts

To protect the control board, each Integrity Series pump will be issued with a Maximum Power limit (Watts). To stay within this limit, the recommended fuse size (Amps) will be based on the voltage supplied. (Watts = Voltage X Amps)

Control Options

- **Direct Supply Voltage:** Speed of the pump determined by the voltage supplied
- **Analog:** 0-5v DC Signal
- **Digital:** PWM
- **CAN-Bus:** Option available
- **Tachometer:** Feedback option available

Maximum Fluid Rating Chart

Controller Position	Maximum Fluid Temp Rating
Separate from pump	225°F (107°C)
Within pump's housing	Not Applicable

Various factors influence the recommended maximum temperature rating. These factors play a role in determining the pump's life and applied warranties. In some applications, a higher maximum fluid temperature rating may be warranted.

Factors influencing maximum temperature rating include, but are not limited to:

- Starting temperature of fluid in system
- Ambient temperature
- Required performance, application's specifications
- Run time

Optional Agency Approvals

UL778: Motor-Operated Water Pumps
NSF61: Potable Water
NSF372: Lead Content

RoHS/REACH

Many GRI pumps are RoHS & REACH compliant. For declarations by specific model numbers, please contact GRI.

IP (Ingress Protection)

IP66: No ingress of dust, protection against powerful water jets.
IP67: No ingress of dust, protection against temporary water immersion.
IP68: No ingress of dust, protection against continuous water immersion.

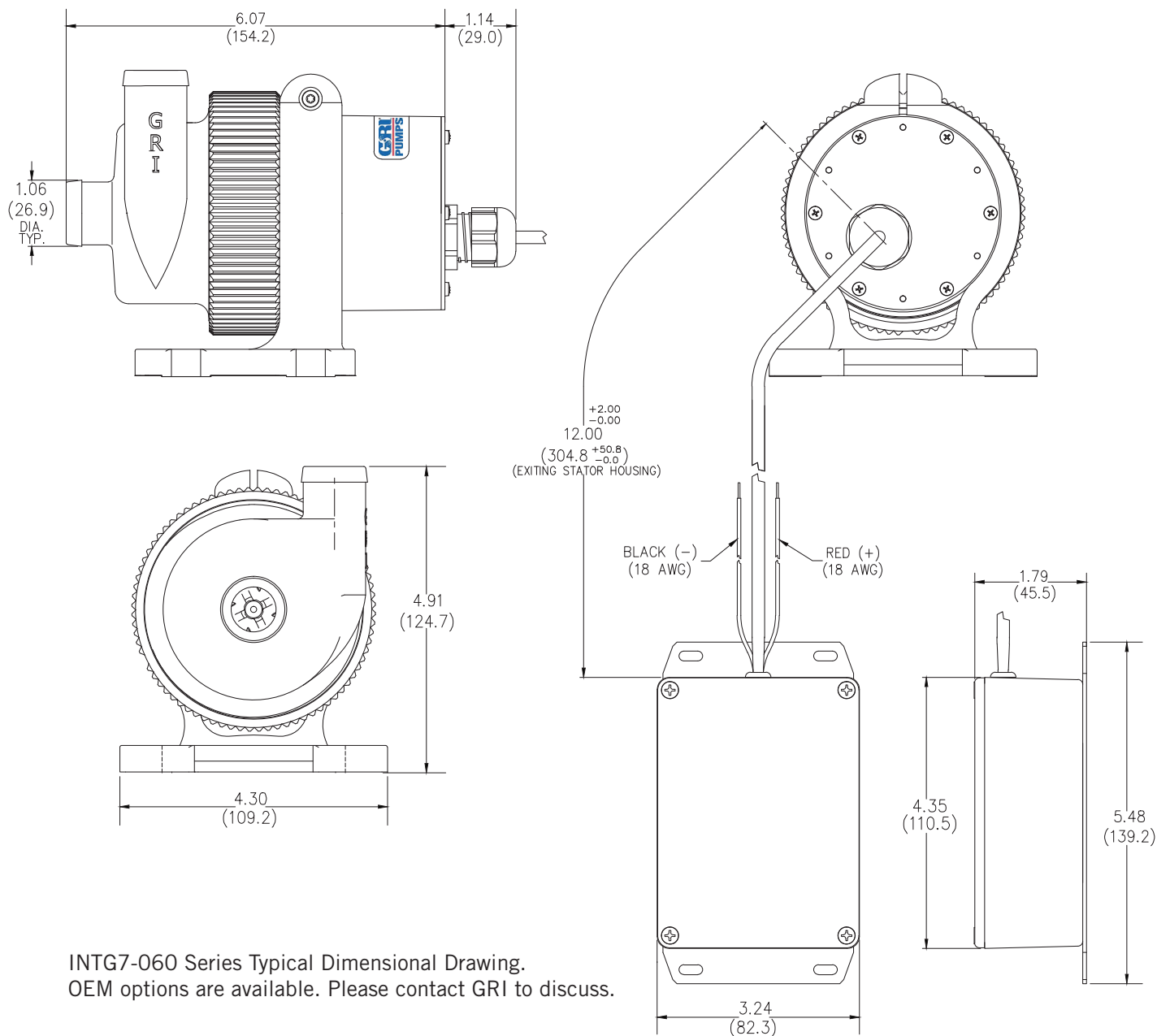

Integrity Series Pumps are designed and manufactured specifically for OEM customization. If you don't immediately find a pump that meets your exact requirements, our dedicated Pump Team is ready to work with you in developing a solution specific to your application.

INTG7 SERIES MODELS				Ports Inches	Max Flow GPM (LPM)	Max Head Ft. (PSI) (m)	Voltage
EPDM O-Ring		FKM O-Ring					
2 wire: (+), (-)	3 wire: (+), (-), Speed Control	2 wire: (+), (-)	3 wire: (+), (-), Speed Control				
INTG7-060	INTG7-062	INTG7-061	INTG7-063	1" MHB	22.0 (83.3)	70.0 (30.3) (21.3)	12-24

Connectors: MHB = Male Hose Barb; | **O-Ring Material:** EPDM = Ethylene Propylene Diene Monomer, FKM = Fluoroelastomer.

INTG8 Series • Maximum flow per voltage						
Voltage	Flow (GPM)	Flow (L)	Ttl. Hd. (Ft)	Ttl. Hd. (PSI)	Ttl. Hd. (BAR)	Ttl. Hd. (M)
48 36vdc	39.29	148.74	13.84	6.00	0.41	4.22
24vdc	37.41	141.62	9.95	4.31	0.30	3.03
21vdc	31.77	120.27	13.58	5.89	0.41	4.14
18vdc	30.12	114.00	9.64	4.18	0.29	2.94
15vdc	26.20	99.19	6.70	2.90	0.20	2.04
12vdc	21.97	83.17	4.07	1.76	0.12	1.24

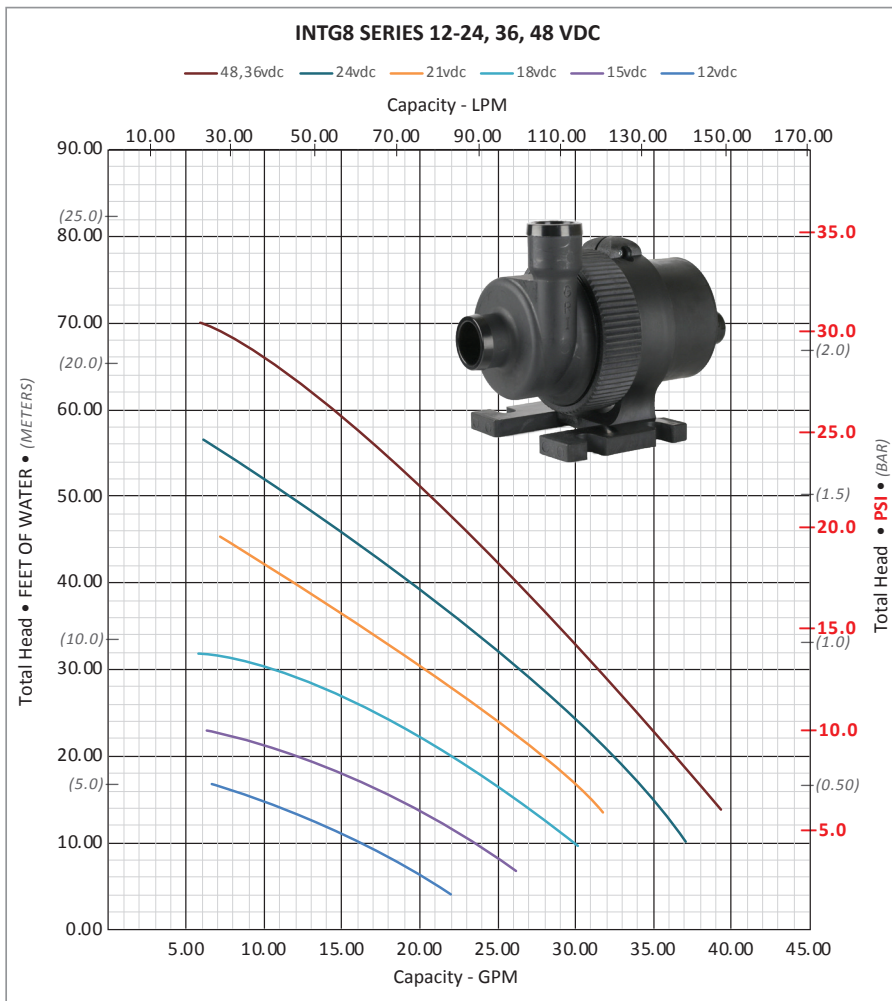

Specifications

Maximum System Pressure: 75 psi
Approximate Weight (w/ external box): 5.1 lbs (2313.32 grams)
Ports: 1.25" MHB

Materials In Contact With Solution

Body: PPS	Housing: PPS	Static O-Ring: EPDM, FKM
Impeller: PPS	Pump Shaft: Ceramic	

Motor Specifications

Motor: Integrated, Brushless DC	Control Options
Supply Voltage: 12-48 VDC	
Electronics Maximum Power: 600 Watts	<ul style="list-style-type: none"> • Direct Supply Voltage: Speed of the pump determined by the voltage supplied • Analog: 0-5v DC signal • Digital: PWM • CAN-Bus: Option available • Tachometer: Feedback option available
<i>To protect the control board, each Integrity Series pump will be issued with a Maximum Power limit (Watts). To stay within this limit, the recommended fuse size (Amps) will be based on the voltage supplied. (Watts = Voltage X Amps)</i>	

Maximum Fluid Rating Chart

Controller Position	Maximum Fluid Temp Rating
Separate from pump	225°F (107°C)
Within pump's housing	Not Applicable

Various factors influence the recommended maximum temperature rating. These factors play a role in determining the pump's life and applied warranties. In some applications, a higher maximum fluid temperature rating may be warranted.

Factors influencing maximum temperature rating include, but are not limited to:

- Starting temperature of fluid in system
- Ambient temperature
- Required performance, application's specifications
- Run time

Available Agency Approvals

Contact GRI
RoHS/REACH
Many GRI pumps are RoHS & REACH compliant. For declarations by specific model numbers, please contact GRI.

Note: Testing performed in a controlled laboratory environment. Actual performance may vary (+) or (-) 10% from the information shown.

Do Not Run Pumps Dry. Pumps must be in a continuous flooded suction environment.

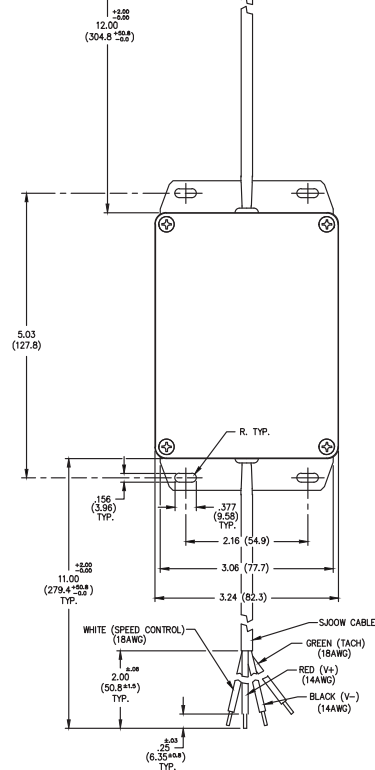
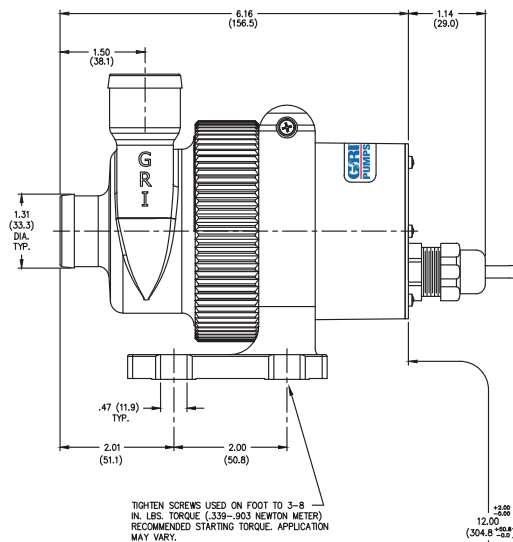
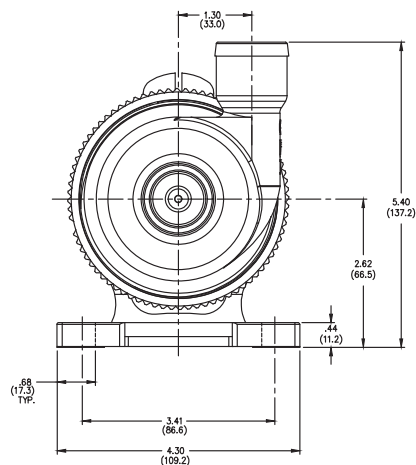

INTG8 Series Typical Dimensional Drawing.
OEM options are available. Please contact GRI to discuss.

Integrity Series Pumps are designed and manufactured specifically for OEM customization. If you don't immediately find a pump that meets your exact requirements, our dedicated Pump Team is ready to work with you in developing a solution specific to your application.

Model	Voltage	Speed Control	Lead Wires	Max. Flow GPM (LPM)	Max. Head Feet (PSI)	Connections Inlet/ Outlet (Inches)	O-Ring Material
INTG8-242	12-24 VDC	Direct	2 wires (+), (-)	34.0 (130.0)	53.7 (23.0)	1.25 MHB	EPDM
INTG8-244	9-36 VDC	PWM / Analog (0-5v Nominal)	4 wires (+), (-), Speed Control, Tach	34.0 (130.0)	58.0 (25.0)	1.25 MHB	EPDM
INTG8-482	36-48 VDC	Direct	2 wires (+), (-)	38.0 (146.0)	69.0 (30.0)	1.25 MHB	EPDM
INTG8-484	36-60 VDC	PWM / Analog (0-5v Nominal)	4 wires (+), (-), Speed Control, Tach	38.0 (146.0)	75.0 (32.5)	1.25 MHB	EPDM

Connectors: MHB = Male Hose Barb | **O-Ring Material:** EPDM = Ethylene Propylene Diene Monomer, FKM = Fluoroelastomer (Available on request)

Since 1953, GRI has developed a rich history of supplying OEMs around the globe with quality U.S. built, custom designed pumps. This portfolio of time-proven legacy pumps continues to move fluid within a wide array of OEM applications around the globe.

For more information please contact your territory manager or visit www.GRIpumps.com/pumps



Bellows Metering

GRI Bellows Metering Pumps use a proprietary bellows and valving technology to provide an accurate, durable, long-lasting, chemically resistant metering pump.



Bellows Dosing

Bellows Dosing Pumps are ideal for low flow, low pressure metering applications where a fixed flow rate is required.

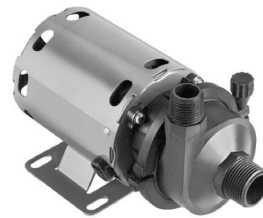

Magnetic Drive Centrifugal

Magnetic Drive Centrifugal Pumps are corrosion resistant, quiet, hydraulically efficient, leak-free (contain no shaft seals), and are customizable for many OEM applications.



Centrifugal

Centrifugal Pumps are designed to transfer both corrosive and non-corrosive fluids at maximum hydraulic efficiencies.



Gear

Gear Pumps are designed primarily for metering and transfer applications. Their modular design allows a wide variation of flow ranges with a standard parts set.



Piston Diaphragm

Piston Diaphragm Pumps are positive displacement pumps designed to economically transfer small volumes of fluid at low discharge pressures.

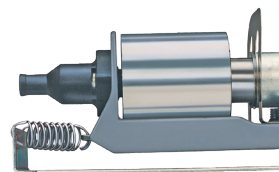

Oscillating Pumps

Oscillating Pumps are self-priming, corrosion resistant, have no dynamic seals, and are constructed from FDA accepted materials.

International Sales



Jody Hastings
General Manager
(419) 886-5208
JHastings@gripumps.com



Tina Spearman
International Sales Manager
(419) 886-5254
TSpearman@gripumps.com

North American Sales



Aaron Hill
Eastern Territory Manager
(419) 886
AHill@gripumps.com



Jeremy Stapleton
Western Territory Manager
(419) 886-5247
Jeremy.Stapleton@gripumps.com



Mandy Simmons
Inside Sales Coordinator
(419) 886
Mandy.Simmons@gripumps.com

The Pump People®

Sales & Marketing Support



Victor Swisher
Director of Engineering
(419) 886-5214
VSwisher@gripumps.com



Jim Fehrman
Marketing Manager
(419) 886-5219
JFehrman@gripumps.com



Join our mailing list

www.GRIpumps.com

MADE IN AMERICA'S HEARTLAND. TRUSTED AROUND THE WORLD.



GORMAN-RUPP INDUSTRIES
180 HINES AVENUE
BELLVILLE, OH 44813 USA
PHONE: 419-886-3001 FAX: 419-886-2338
GRIpumps.com



Product information is subject to change; consult factory for details. ©2020 GRI Pumps. All rights reserved. Printed in the USA.

