

DIVISION OF THE GORMAN-RUPP COMPANY
Phone (419) 886-3001 • FAX (419) 886-2338
grisales@gripumps.com • www.gripumps.com

SINGLE STROKE BELLOWS DISPENSING PUMP

DESCRIPTION

The single stroke dispensing bellows pump size is the actual outside diameter of the bellows. The pump operates on an adjustable stroke, positive displacement principle. Output of the bellows is adjusted by changing the stroke. The pump is driven by a thermally protected gear-motor attached to an adjustable connecting rod assembly. All standard wetted parts, except the valve poppet, are polypropylene.

Exposure of the motor to extremely dusty or corrosive environment may reduce life.

PRIMING

The pump is self-priming under most conditions: however, the priming ability lessens with greater suction lift, higher discharge head, or with reduced stroke. For dry start up on pumps with anti-siphon spring adjusted at low stroke, pump may not prime. Remove anti-siphon spring, prime pump and replace spring.

After the pump has been primed and is full of liquid, subsequent repriming ability will be improved.

FLOW ADJUSTMENT

Flow rate is changed by turning an adjusting nut (knurled ring) on the threaded connecting

rod. Turning the ring toward the bellows decreases pump output. Turning the ring toward the crank increases pump output.

Do not reduce output flow by restricting suction or discharge as this will cause excessive pressure within the pump.

PRESSURE

The bellows pump has the ability to discharge into a pressurized system; however, if system or discharge pressure exceeds maximum psi rating of bellows, it may cause damage to the bellows or gearbox.

Maximum PSI Rating:

- 1" modules pump – 40 psi
- 1½" modules pump – 20 psi
- 2½" modules pump – 5 psi

NOTE: Pumps are designed for use with liquid up to 120°F (49°C) at catalog rated pressure. Reduce the maximum psi rating by 50% for temperatures over 120°F. Not applicable in liquids over 140°F.

VISCOSITY

The pump has been designed to handle a wide range of liquid viscosities. It should be noted, however, that when pumping thicker liquids it may be necessary to increase the size of

connectors and tubing to relieve the pressure buildup within the pump assembly. It is good practice when pumping the heavier liquids to keep the liquid velocity (pump speed) as low as possible.

When pumping heavy suspensions which may tend to settle out, extremely corrosive solutions or any liquid which may tend to become more viscous with time, flush pump after use to increase pump life.

CHEMICAL SERVICE

The bellows pump will handle many different kinds of liquids. For specific chemical service, refer to our Full Line Catalog, Form No. 86216.

Special bellows materials (chlorine resistant and acid resistant) are available. Chlorine resistant bellows are available in 1", 1½" and 2½" sizes. Pumps using chlorine resistant bellows should have pressure ratings shown in the paragraph under pressure heading reduced by 50%. Acid resistant bellows are available in 1" and 1½" sizes only, and standard pressures apply.

TEMPERATURE

Pumps are designed to operate in 80°F (27°C) ambient temperature. For higher ambient temperature operations, consult the factory.

TROUBLESHOOTING GUIDE

The troubleshooting guide is a suggestion or aid in helping solve problems that might arise.

NOTE: Never work on pump without making certain power is off.

PUMP LEAKS

1. Bellows loose - Turn adjusting nut (knurled ring) to full stroke, then rotate crank assembly to maximum bellows compression. Tighten plastic nut on connecting rod to 14 in.-lbs. maximum. **CAUTION:** Overtightening will distort bellows and cause leaks.
2. Connectors loose – Tighten to 5½ to 6½ in.-lbs. torque (finger tight).
3. O-ring defective or missing – See illustration.

MOTOR WILL NOT RUN

1. Switch defective.
2. Wires pulled loose.
3. Motor overtemperature thermostat open, motor overheating or poor ventilation.

UNIT WILL NOT PRIME

1. Pump leaks on suction side (see "Pump Leaks" section).
2. Bellows ruptured.
3. O-ring defective or missing – See illustration.
4. Valves inverted or reversed.
5. Pump air-locked – Temporarily bleed off discharge pressure.
6. Stroke too short – Adjust knurled ring to increase stroke.
7. Viscosity too high.
8. Anti-siphon spring with pump adjusted at low stroke.

PUMP NOISY

1. Fan hitting.
2. Gearmotor worn out.

ERRATIC OR LOW FLOW

1. Valves dirty – Dirt or foreign material in valves.
2. Crank set screw broken.
3. Valves not seating.
4. Connectors loose.

UNIT WILL NOT PUMP

1. Bellows ruptured.
2. Crank broken.
3. Crank set screw broken.
4. Valves dirty – Dirt or foreign material in valves.
5. Valves may have deteriorated.

WARRANTY

Gorman-Rupp Industries warrants to Buyer that products sold by it will upon shipment conform to the description on the face hereof and any written specifications expressly approved by Seller and be free from defects in title, material and workmanship. NO OTHER WARRANTY, WHETHER EXPRESS OR IMPLIED, INCLUDING ANY WARRANTY OF MERCHANTABILITY OR FITNESS FOR A PARTICULAR PURPOSE, SHALL EXIST IN CONNECTION WITH ANY PRODUCTS SOLD BY SELLER, AND ALL SUCH WARRANTIES ARE HEREBY EXPRESSLY EXCLUDED.

WARNING

DANGER:

Improper application, installation, adjusting, or servicing can result in serious injury or death. Always disconnect power source before working on these products.

Caution:

Products with electric motors must be properly grounded and may start automatically at any time. For product information, consult Gorman-Rupp Industries, Bellville, Ohio 44813, Phone (419) 886-3001.

EXPLODED VIEW – SINGLE STROKE BELLOWS DISPENSING PUMP

TO ORDER REPLACEMENT PUMPS, OR KITS, CALL YOUR LOCAL GRI DISTRIBUTOR.

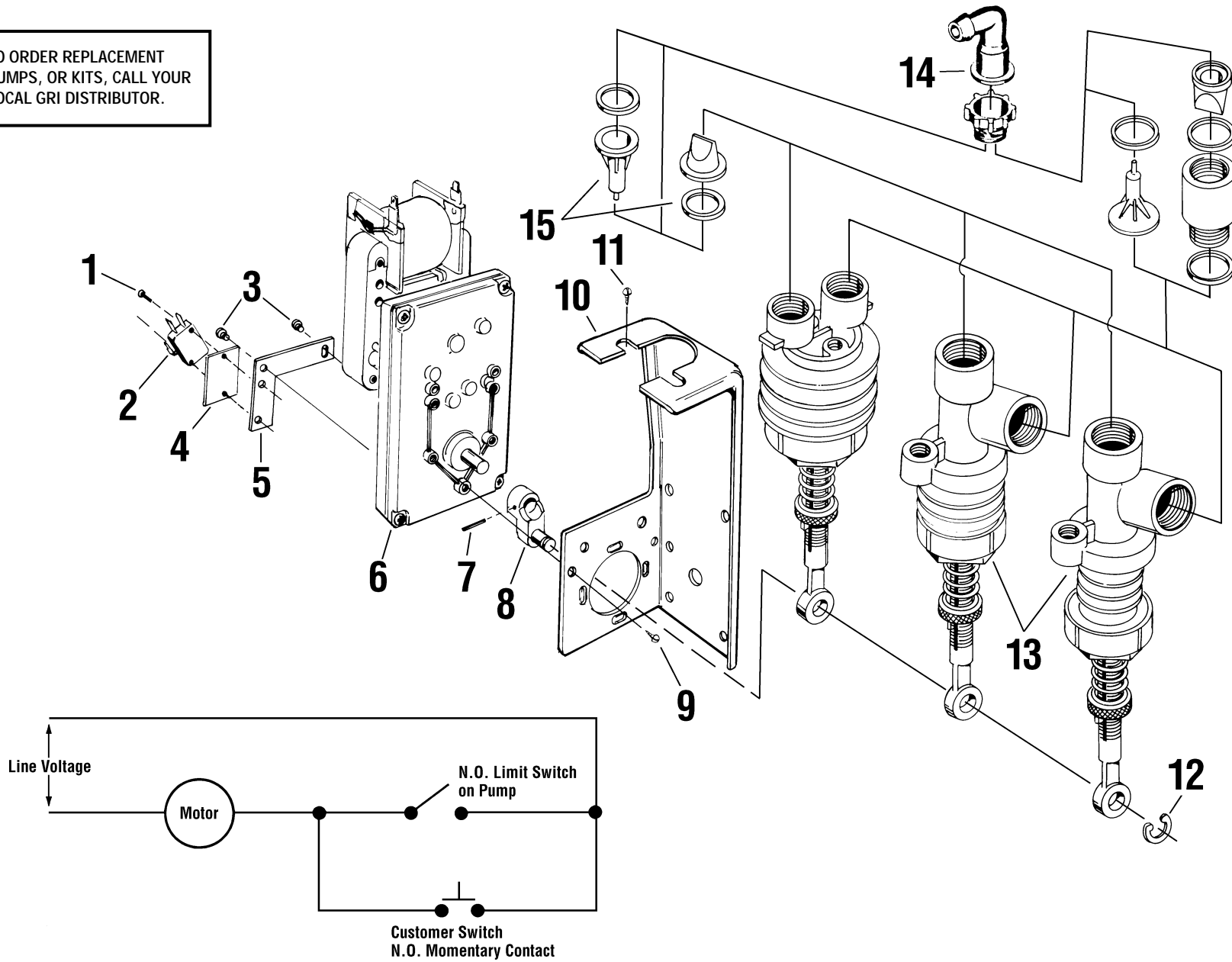

PARTS LIST

ITEM	REQ.	DESCRIPTION	ORDERING INFORMATION
1	2	4-40 Screw	Included in Motor Replacement Kit - See Chart
2	1	Switch	Included in Motor Replacement Kit - See Chart
3	2	8-32 Screw	Included in Motor Replacement Kit - See Chart
4	1	Insulation Board	Included in Motor Replacement Kit - See Chart
5	1	Switch Plate	Included in Motor Replacement Kit - See Chart
6	1	Gearmotor	Included in Motor Replacement Kit - See Chart
7	1	Spring Pin	Included in Crank Assembly Replacement Kit - See Chart
8	1	Crank Arm	Included in Crank Assembly Replacement Kit - See Chart
9	4	8-32 Motor Mtg. Screw	Included in Motor Replacement Kit - See Chart
10	1	Mounting Bracket	See note below
11	2	1/4-14 Screw	Included in Bellows Module Replacement Kit - See Chart
12	1	Retaining Ring	Included in Bellows Module Replacement Kit - See Chart
13	1	Bellows Assembly	Included in Bellows Module Replacement Kit - See Chart
14	2	Connectors	Included in Tubing Connector Replacement Kit - See Chart
15	2	Poppet Valve Assembly	Included in Poppet Valve Replacement Kit - See Chart

NOTE: Parts not available unless stocked by GRI Distributor or purchased in OEM quantities.

MOTOR REPLACEMENT KITS

115 VOLT		240 VOLT	
MOTOR	KIT NUMBER	MOTOR	KIT NUMBER
10 RPM	02501-091	10 RPM	02501-090

Kit includes Motor Mounting Screws, Switch, Switch and Plate Screws, Insulation Board, Switch Plate and Gearmotor.

VALVE ASSEMBLY PROCEDURE

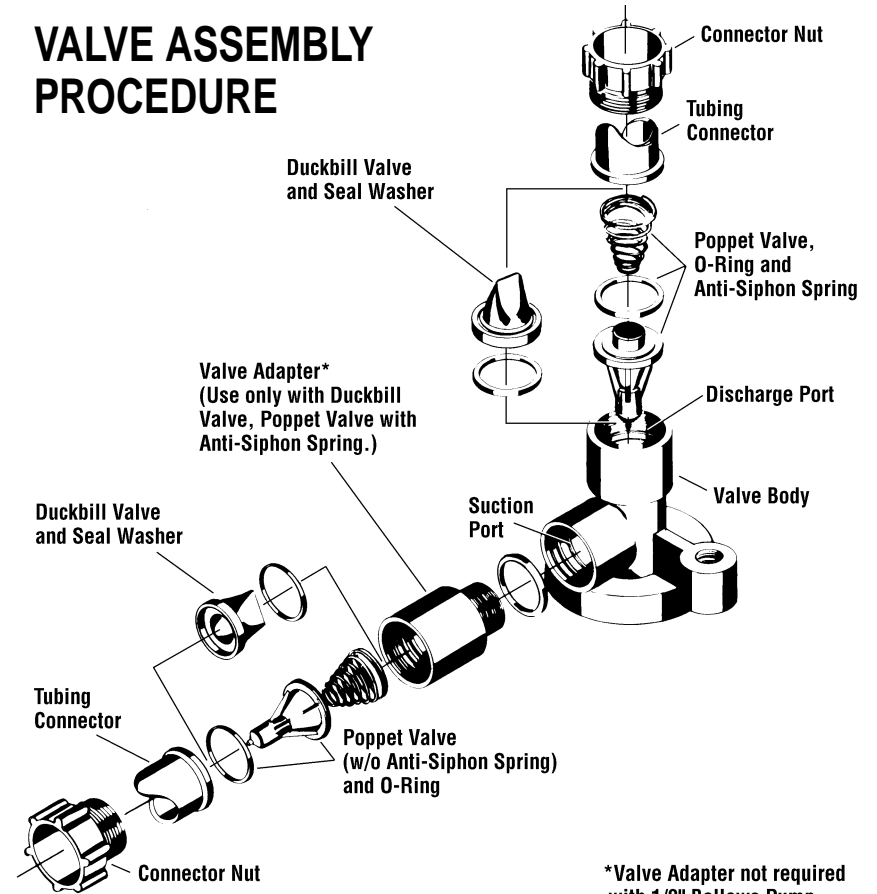

BELLOWS MODULE REPLACEMENT KITS

BELLOWS SIZE	HYPALON®	EPT	VITON®/ FLUOROELASTOMER
1"	02500-968	02501-647	02500-973
1-1/2"	02500-886	02501-646	02500-965
2-1/2"	02500-460	02500-649	02500-652



NOTE: Kit includes Connecting Rod Assembly, Bellows Module, Displacement Cup, Screws, O-Rings and Retaining Ring.

CRANK ASSEMBLY REPLACEMENT KITS

BELLOWS SIZE	KIT NUMBER
1", 1-1/2"	02501-093
2-1/2"	02501-092

Kit includes Spring Pin and Crank Assembly.

TUBING CONNECTORS (2 PER KIT) – POLYPROPYLENE

			
BELLOWS SIZE	1/4" ID x 3/8" OD COMPRESSION (LARGE)	3/8" ID ELBOW	1/2" ID ELBOW
1", 1-1/2"	T-007 (02500-260)	T-008 (02500-261)	T-009 (02500-354)
2-1/2"		T-008 (02500-261)	T-009 (02500-354)

NOTE: "T" codes are used for identification purposes only, to show tubing connectors used in pump. Use "T" code on label as a guide. Use 8-digit kit number beside corresponding "T" code when ordering replacement tubing connector kit.

Example: If T-008 is on pump label, order kit number 02500-261. Kit includes (2) Connectors and (2) Connector Nuts.

POPPET AND DUCKBILL VALVE KITS

POPPET VALVE KITS			
BELLOWS SIZE	HYPALON®	EPT	VITON®/ FLUOROELASTOMER
1", 1-1/2", 2-1/2"	X-115 or X-125 (02500-608)	X-112 or X-122 (02500-605)	X-116 or X-126 (02500-609)



1", 1-1/2" & 2-1/2" Poppet Valve Kit

DUCKBILL VALVE KITS			
BELLOWS SIZE	HYPALON®	EPT	VITON®/ FLUOROELASTOMER
1", 1-1/2", 2-1/2"	X-035 or X-045 (02500-325)	X-032 or X-042 (02500-322)	X-036 or X-046 (02500-319)



1", 1-1/2" & 2-1/2" Duckbill Valve Kit

NOTE: "X" codes are used for identification purposes only, to show elastomer in pump. Use "X" codes on pump label as a guide. Use 8-digit kit number beneath corresponding "X" code when ordering replacement valve kit.

Example: If X-115 is on pump label, order kit number 02500-608.

Registered Trademark Names

VITON® DuPont Dow Elastomers
HYPALON® DuPont Dow Elastomers



DIVISION OF THE GORMAN-RUPP COMPANY
Phone (419) 886-3001 • FAX (419) 886-2338
grisales@gripumps.com • www.gripumps.com