

Piston Diaphragm Pumps

Piston Diaphragm Pumps are positive displacement pumps designed to economically transfer small volumes of fluid at low discharge pressures. The lightweight, compact pumps are self-priming, corrosion resistant and can handle viscous fluids. These features make the pumps ideal for high-volume copy machines, scientific and laboratory instruments, and other chemical dispensing applications.

Features:

- Economical
- Self-priming
- No dynamic seals
- No backflow
- Continuous duty rated
- Corrosion resistant
- Dry run capability

Operation:

Standard models are constructed with 12 or 24 volt DC solenoids. A switch is required to supply pulsed voltage to the pump. The energized solenoid pulls the piston and diaphragm up, drawing fluid into the pump. A spring forces the piston back to its original position when the solenoid is de-energized, forcing fluid out of the pump, and the cycle is repeated. Valves are utilized to prevent back-flow into the pump and to maintain prime.



Specifications

Max Flow	Range to 250 microliters per stroke.
Max Discharge Pressure	Range to 2.6 psi (6').
Self Priming	To 3 feet
Max. Fluid Viscosity	To 300 centistokes
Max Fluid Temp.	200°F (93°C)
Typical Duty Cycle	1 cycle/second (1/2 sec. on – 1/2 sec. off)
Metering Accuracy	±2% stroke-to-stroke (for a stationary setup)
I.D. Tubing Size	3/16"
Positive suction head above 6" requires tight valves; consult factory for availability.	

Specifications / OEM Options

Piston Diaphragm Pumps

OEM Options

To meet OEM application requirements, the following options can be added:

- Fixed flow up to 500 microliters per stroke for low heads.
- Fixed flow can be down to 100 microliters per stroke.
- Field adjustability with screw and locking nut.
- Alternate materials of construction.
- To improve accuracy and increase flow rate, **Stepper Linear Actuator** can replace solenoid.
- **Multiple solenoid voltage** options and **stroke limiters** available to assist with improving accuracy.

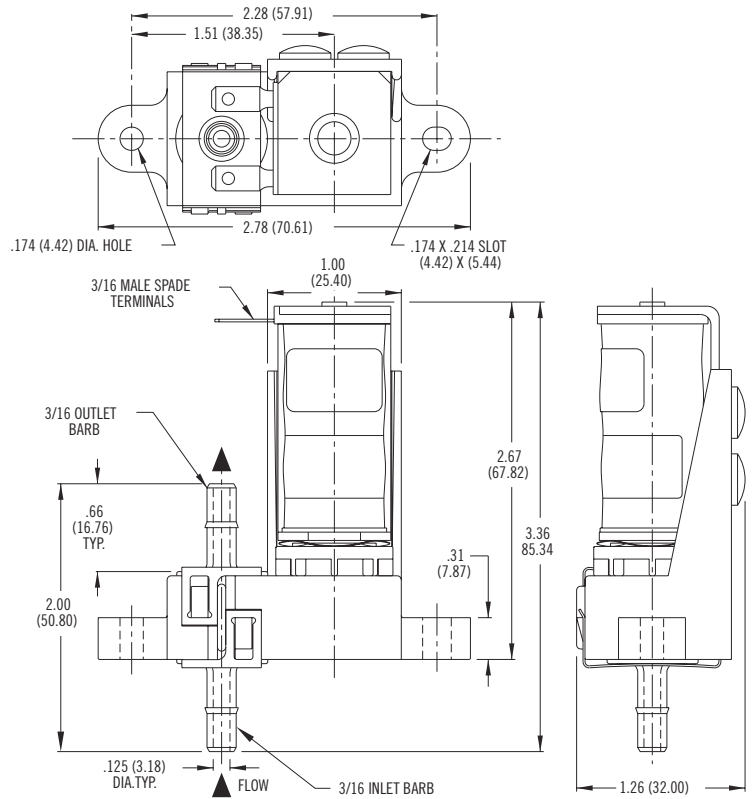

Dimensions in Inches (Dimensions in Millimeters)

Model Number	Voltage	Elastomer	Wetted Plastic	Max Fluid Temp.	Connections Inlet/Outlet	Weight
16160-001	24VDC	EPT/EPDM	Noryl®	203°F / 95°C	3/16" MHB	.265 lb.
16160-002	12VDC	Nitrile	Polypropylene	185°F / 85°C	3/16" MHB	.265 lb.
16160-003	24VDC	Nitrile	Polypropylene	185°F / 85°C	3/16" MHB	.265 lb.
16160-004	12VDC	EPT/EPDM	Noryl®	203°F / 95°C	3/16" MHB	.265 lb.
16160-005	24VDC	EPT/EPDM	Polypropylene	185°F / 85°C	3/16" MHB	.265 lb.
16160-006	12VDC	EPT/EPDM	Polypropylene	185°F / 85°C	3/16" MHB	.265 lb.
16160-007	24VDC	Nitrile	Noryl®	203°F / 95°C	3/16" MHB	.265 lb.
16160-008	12VDC	Nitrile	Noryl®	203°F / 95°C	3/16" MHB	.265 lb.