

Mini Bellows Pumps

Mini Bellows models are ideal for low flow, low pressure metering applications. The pump is constructed entirely of plastic and utilizes

GRI's time-proven bellows technology to provide an accurate chemically-resistant metering pump with a long life, at an economical price.

Features:

- Average repeatability from stroke-to-stroke, $\pm 0.75\%$
- Dry run capability
- Self-priming
- No dynamic seals
- Superior corrosion resistance
- Simple flow adjustment

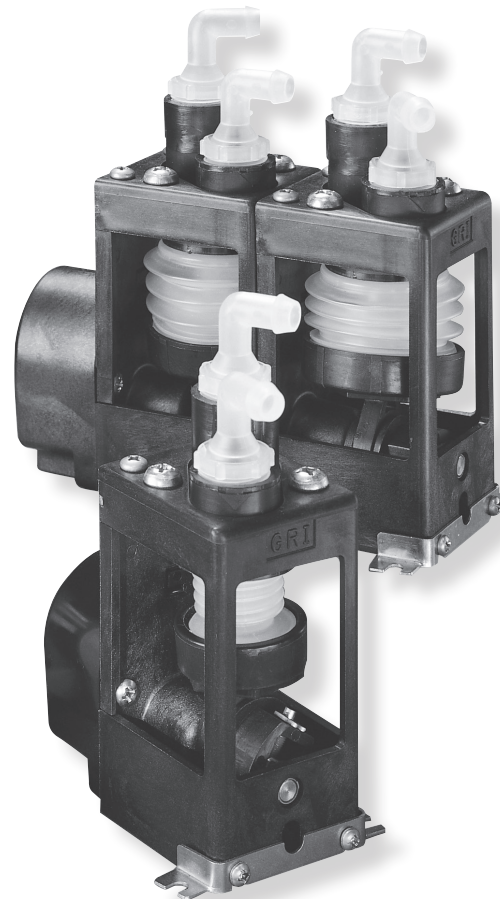
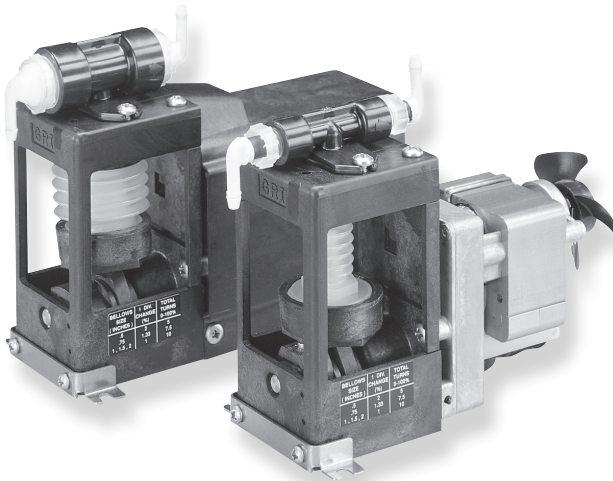

Contents	Pages
• Overview	2-4
• Single Mini Selection Guide.....	5-6
• Tandem Mini Selection Guide	7-8
• Options.....	9-10
• Accessories	11
• Replacement Kits	12-13
• Typical Dimensions	14-15
• Exploded View	16



Mini Bellows Metering Pumps Product Overview

Mini Bellows Metering Pumps are ideal for low flow, low pressure metering applications. The pump is constructed entirely of plastic and uses GRI's time-proven bellows technology to provide an accurate chemically-resistant metering pump with a long life, at an economical price.

Mini Bellows Metering Pump Operation:

The Mini Bellows Metering Pumps operate on a positive displacement principle. The rotation of the motor shaft is transmitted into an up and down linear motion through an adjustable concentric crank mechanism. This motion provides a continuous compressing and relaxing force on the bellows module, forcing fluid between two check valves located in the module's valve body. Up to two separate bellows modules can be operated by single motor for proportioning up to four separate fluid mediums. The flow rate of each module is independently adjustable. Multiple bellows modules operate out-of-phase with each other for most efficient power usage.

Optimum Operating Conditions:

Optimum operating conditions consist of a 6" minimum suction life and a discharge head of not less than 6". Pumps must be mounted vertically with the valve body at the top to obtain maximum metering accuracy. For conditions where a positive suction head condition exists, an anti-siphon spring or anti-siphon spring kit can be added to aid the poppet valve seal properly during operation. See pages 12 and 13 for Accessories.

Flow Rates:

The flow rate of each bellows module is regulated by three factors:

1. Diameter of the bellows,
2. Speed of the gearmotor,
3. Adjustment of the module stroke length.

The full stroke displacement and discharge pressure of the pump is dependent on the size of the bellows as shown below. If higher discharge pressure is required, please consult factory for an OEM solution.

COMPATIBLE MINI BELLOWS MODULE FLOW RATE CHART										
Bellows Size	1/2"	3/4"	1"	1 1/2"	2"					
Full Stroke Displacement (ml)	.5	1.8	5	10.5	18					
Max Discharge Pressure (psi)	5	5	5	5	5					
Motor RPM	Max Flow per Module (ml/min)									
	50 Hz	60 Hz	50 Hz	60 Hz	50 Hz	60 Hz	50 Hz	60 Hz	50 Hz	60 Hz
8	3.3	4.0	12.0	14.4	33.3	40.0	70.0	84.0	120.0	144.0
12	5.0	6.0	18.0	21.6	50.0	60.0	105.0	126.0	180.0	216.0
15	6.2	7.5	22.5	27.0	62.5	75.0	131.3	157.5	225.0	270.0
24	10.0	12.0	36.0	43.2	100.0	120.0	210.0	252.0	—	—





The Pump People

Flow Adjustment:

The 1/2" and 3/4" bellows modules can be adjusted to 20% of maximum stroke length, while 1", 1-1/2" and 2" bellows modules can be adjusted down to 10% of maximum stroke.

Note: Best priming and metering accuracy occurs when the stroke length is 50% or greater.

Standard Crank - Adjustment cannot be made while pump is operating. An adjusting screw changes the stroke length of an eccentric crank.

Mini Bellows Metering Pump Specifications:

Average Repeatability - From stroke-to-stroke ± 0.75%

Flow Rates - Range to 270 ml/min, Tandem models range to 432 ml/min

Max Discharge Pressure - To 6 psi.

Max Fluid Temperatures - To 140°F (60°C)

Note: Reduce pressure rating by 50% for fluid temperatures over 120°F (49°C).

Viscosity/Slurries - Maximum fluid viscosity is 5,000 centistokes. Poppet valves can handle fine slurries. Duckbill valves are recommended for heavy slurries or fibrous materials. Heavy slurries should be flushed from the pump before shutdown.

MAXIMUM DRY AND WET PRIMING SPECIFICATIONS • Feet (Meters)				
Bellows Sizes	Dry Prime 50% of Full Stroke	Dry Prime 100% of Full Stroke	Wet Prime 50% of Full Stroke	Wet Prime 100% of Full Stroke
1/2"	2.5 (.76)	8.67 (2.64)	5.83 (1.78)	17.17 (5.23)
3/4"	1.08 (.33)	3.75 (1.14)	2.5 (.76)	6.25 (1.91)
1"	3.08 (.94)	8.33 (2.54)	6.25 (1.19)	14.25 (4.34)
1 1/2"	4.33 (1.32)	11.00 (3.35)	9.58 (2.92)	20.58 (6.27)
2"	8.08 (2.46)	16.67 (5.08)	12.75 (3.89)	23.50 (7.16)

Note: All testing is done with water at an ambient temperature of 80 degree F. If specific gravity or viscosity of fluid being pumped is significantly greater than water (1.0), please consult factory.





The Pump People®

Gearmotors:

The standard motor available for the Mini Bellows Pump is an AC voltage synchronous motor. Motors are UL recognized and continuous duty rated and are available in 115V, 50/60 Hz or 230V, 50/60 Hz.

Materials in Contact with Solution:

Connectors - Polypropylene

O-Rings (Elastomers) - EPT/EPDM or Viton®/Fluoroelastomer

Poppet - EPT/EPDM or Viton®/Fluoroelastomer

Bellows - Standard Polypropylene Materials

Additional materials available, refer to OEM Section for details.

Mini Bellows Metering Pump Selection:

The pump selection procedure is detailed in the Mini Bellows Metering Pump Selection Guide (pages 5-6) or the Tandem Mini Bellows Pumps Selection Guide (pages 7-8).



Select a bellows size that meets your pressure requirements. Select a model with the bellows size that provides your required flow while operating closest to full stroke capacity. Best metering accuracy occurs when bellows modules operate at 50% or more of maximum output. For 24 hour continuous duty service, use one of the heavy-duty models.

Select a valve and O-ring combination and tubing connectors for each bellows from the selection charts. Specify duckbill valves if heavy slurries or fibrous materials are being pumped.

Order Notes: When ordering a mini bellows model, refer to steps 1 through 3 and follow the example provided.

Example: The model number and codes for a single pump with 1" bellows module with EPT/EPDM elastomers, and a 3/8" barbed connector, driven by a 115V, 8 RPM, 50/60 Hz, motor would be: 16200-003 X-112 T-003.

- Using **Chart A** and **B**, select bellows module(s) and a motor RPM combination whose maximum output meets or exceeds your flow requirements. Best metering accuracy occurs when bellows modules operate at 50% or more of their maximum output. Then refer to **Chart E** to select an appropriate model number. If T-head valve body is required, please consult factory.

CHART A

BELLOWS MODULE OUTPUT

Bellows Size	1/2"	3/4"	1"	1 1/2"	2"
Full Stroke Displacement (ml)	.5	1.8	5	10.5	18

CHART B

MAXIMUM FLOW/ MAXIMUM PRESSURE - SINGLE PUMPS

Max Flow (ml/min)	Bellows Size									
	1/2"		3/4"		1"		1 1/2"		2"	
Motor RPM	50 Hz	60 Hz	50 Hz	60 Hz	50 Hz	60 Hz	50 Hz	60 Hz	50 Hz	60 Hz
8	3.3	4.0	12.0	14.4	33.3	40.0	70.0	84.0	120.0	144.0
15	6.2	7.5	22.5	27.0	62.5	75.0	131.3	157.5	225.0	270.0
24	10.0	12.0	36.0	43.2	100.0	120.0	210.0	252.0	—	—

- Using **Chart D**, select the appropriate X-code for each module's O-ring, and poppet or duckbill valve elastomers.

CHART D

O-RING AND POPPET/DUCKBILL VALVE OPTIONS

Materials	Bellows Size					
	1/2"		3/4", 1" & 1 1/2"		2"	
	Poppet	Duckbill	Poppet	Duckbill	Poppet	Duckbill
EPT/EPDM	X-002	X-092	X-112	X-032*	X-142	X-152*
Viton®/ Fluoroelastomer	X-006	X-096	X-116	X-036*	X-146	X-156*

- Using Tubing Connector **Chart G**, select one T-code.

* Duckbill valves can only be used with T-Head valve body on 3/4", 1", 1-1/2", & 2" pumps

Continued on next page

CHART E

SELECTED SINGLE MINI BELLOWS PUMPS				
Model Number	RPM@ 60 Hz	Bellows Size	Volts	Hz
16200-023	8	1/2"	115	50/60
16200-024	8	1/2"	230	50/60
16200-025	15	1/2"	115	50/60
16200-026	15	1/2"	230	50/60
16200-027	24	1/2"	115	50/60
16200-028	24	1/2"	230	50/60
16200-001	8	3/4"	115	50/60
16200-002	8	3/4"	230	50/60
16200-009	15	3/4"	115	50/60
16200-010	15	3/4"	230	50/60
16200-031	24	3/4"	115	50/60
16200-032	24	3/4"	230	50/60
16200-003	8	1"	115	50/60
16200-004	8	1"	230	50/60
16200-011	15	1"	115	50/60
16200-012	15	1"	230	50/60
16200-029	24	1"	115	50/60
16200-030	24	1"	230	50/60
16200-005	8	1 1/2"	115	50/60
16200-006	8	1 1/2"	230	50/60
16200-013	24	1 1/2"	115	50/60
16200-014	24	1 1/2"	230	50/60
16200-017	15	1 1/2"	115	50/60
16200-018	15	1 1/2"	230	50/60
16200-007	8	2"	115	50/60
16200-008	8	2"	230	50/60
16200-019	15	2"	115	50/60
16200-020	15	2"	230	50/60

CHART G

T-CODES			
T-Code	For Elastomeric Tubing Size	Connector Type	Bellows Module Size
T-001	1/8" I.D. x 1/4" O.D.	Barbed Compression	1/2"
T-002	1/4" I.D. x 3/8" O.D.	Barbed Compression	1/2"
T-003	3/8" I.D.	Barbed	3/4", 1", 1 1/2" & 2"
T-004	1/2" I.D.	Barbed	3/4", 1", 1 1/2" & 2"
T-005	1/8" pipe thread	Female NPT	3/4", 1", 1 1/2" & 2"
T-006**	1/8" I.D. x 1/4" O.D.	Barbed Compression	3/4"
T-007**	1/4" I.D. x 3/8" O.D.	Barbed Compression	3/4", 1", 1 1/2" & 2"
T-008	3/8" I.D.	Elbow Swivel, Barbed	3/4", 1", 1 1/2" & 2"
T-009	1/2" I.D.	Elbow Swivel, Barbed	3/4", 1", 1 1/2" & 2"
T-011	1/4" I.D.	Elbow Swivel, Barbed	3/4", 1", 1 1/2" & 2"
T-012*	4mm (5/32") I.D.	Elbow Swivel, Barbed	3/4"
T-013*	4mm (5/32") I.D.	Elbow Swivel, Barbed	1/2"
T-014	1/4" I.D.	Barbed	3/4", 1", 1 1/2" & 2"

For flows of 1800 ml/min and above. 1/2" I.D. tubing connectors recommended.

*Use of 4mm connector is limited by flow rate; please contact factory with specifications.

**Cost added for connector.

Tubing Connectors (T-Codes)

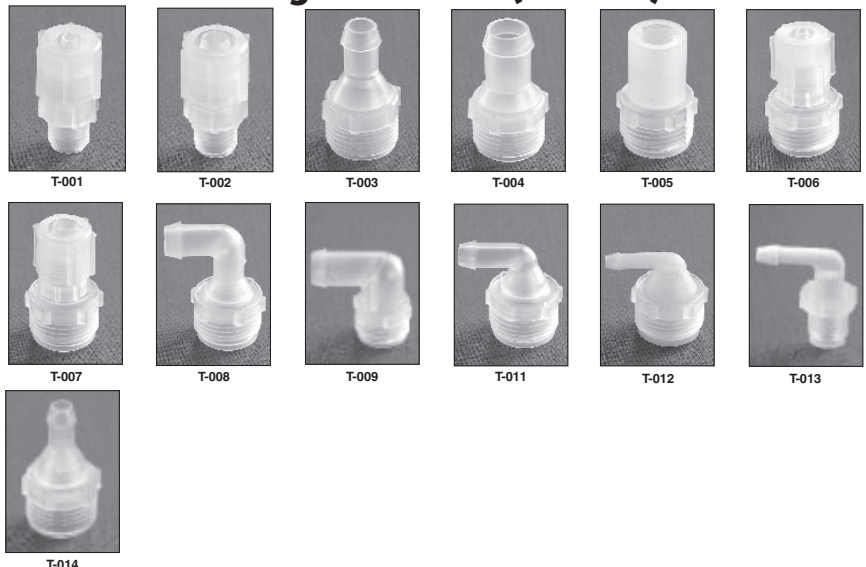

Pump Selection Guide

Tandem Mini Bellows Pumps

Select a bellows size that meets your pressure requirements. Select a model with the bellows size that provides your required flow while operating closest to full stroke capacity. Best metering accuracy occurs when bellows modules operate at 50% or more of maximum output. For 24 hour continuous duty service, use one of the heavy-duty models.

Select a valve and O-ring combination and tubing connectors for each bellows from the selection charts. Specify duckbill valves if heavy slurries or fibrous materials are being pumped.

Order Notes: When ordering a mini bellows model, refer to steps 1 through 3 and follow the example provided.

Example: The model number and codes for a 2-tandem pump with 1" bellows module, with EPT/EPDM elastomers and 3/8" barbed connector and a 1" bellows module with Viton® Fluoroelastomer elastomers and a 3/8" elbow connector, all driven by a 115V, 8 RPM, 50/60 Hz, motor would be: 16220-011 X-112 T-003 X-116 T-008.

- Using **Chart A and C**, select bellows module(s) and a motor RPM combination whose maximum output meets or exceeds your flow requirements. Best metering accuracy occurs when bellows modules operate at 50% or more of their maximum output. Then refer to **Chart F** to select an appropriate model number. If T-head valve body is required, please consult factory.

CHART A

BELLOWS MODULE OUTPUT

Bellows Size	1/2"	3/4"	1"	1 1/2"	2"
Full Stroke Displacement (ml)	.5	1.8	5	10.5	18

- Using **Chart D**, select the appropriate X-code for each module's O-ring, and poppet or duckbill valve elastomers.

CHART C

MAXIMUM FLOW/ MAXIMUM PRESSURE - TANDEM PUMPS

Max Flow* (ml/min)	Bellows Size									
	1/2" x 1/2"		3/4" x 3/4"		1" x 1"		1 1/2" x 1 1/2"		2" x 2"	
Motor RPM	50 Hz	60 Hz	50 Hz	60 Hz	50 Hz	60 Hz	50 Hz	60 Hz	50 Hz	60 Hz
8	6.6	8.0	24.0	28.8	66.7	80.0	140.0	168.0	240.0	288.0
15	12.5	15.0	45.0	54.0	125.0	150.0	262.5	315.0	450.0	540.0
24	20.0	24.0	72.0	86.4	—	—	—	—	—	—

- Using Tubing Connector **Chart G**, select one T-code for each X-code chosen from **Chart D**.

CHART D

O-RING AND POPPET/DUCKBILL VALVE OPTIONS

Materials	Bellows Size					
	1/2"		3/4", 1" & 1 1/2"		2"	
	Poppet	Duckbill	Poppet	Duckbill	Poppet	Duckbill
EPT/EPDM	X-002	X-092	X-112	X-032*	X-142	X-152*
Viton®/ Fluoroelastomer	X-006	X-096	X-116	X-036*	X-146	X-156*

Continued on next page

*Duckbill valves can only be used with T-Head valve body on 3/4", 1", 1-1/2", & 2" pumps.

CHART F

SELECTED TANDEM MINI BELLOWS PUMPS				
Model Number	RPM@ 60 Hz	Bellows Size	Volts	Hz
16220-027	8	1/2" x 1/2"	115	50/60
16220-028	8	1/2" x 1/2"	230	50/60
16220-029	15	1/2" x 1/2"	115	50/60
16220-030	15	1/2" x 1/2"	230	50/60
16220-031	24	1/2" x 1/2"	115	50/60
16220-032	24	1/2" x 1/2"	230	50/60
16220-007	24	3/4" x 3/4"	115	50/60
16220-008	24	3/4" x 3/4"	230	50/60
16220-009	8	3/4" x 3/4"	115	50/60
16220-010	8	3/4" x 3/4"	230	50/60
16220-025	15	3/4" x 3/4"	115	50/60
16220-026	15	3/4" x 3/4"	230	50/60
16220-001	15	1" x 1"	115	50/60
16220-002	15	1" x 1"	230	50/60
16220-011	8	1" x 1"	115	50/60
16220-012	8	1" x 1"	230	50/60
16220-003	15	1 1/2" x 1 1/2"	115	50/60
16220-004	15	1 1/2" x 1 1/2"	230	50/60
16220-013	8	1 1/2" x 1 1/2"	115	50/60
16220-014	8	1 1/2" x 1 1/2"	230	50/60
16220-005	15	2" x 2"	115	50/60
16220-006	15	2" x 2"	230	50/60
16220-015	8	2" x 2"	115	50/60
16220-016	8	2" x 2"	230	50/60

CHART G

T-CODES			
T-Code	For Elastomeric Tubing Size	Connector Type	Bellows Module Size
T-001	1/8" I.D. x 1/4" O.D.	Barbed Compression	1/2"
T-002	1/4" I.D. x 3/8" O.D.	Barbed Compression	1/2"
T-003	3/8" I.D.	Barbed	3/4", 1", 1 1/2" & 2"
T-004	1/2" I.D.	Barbed	3/4", 1", 1 1/2" & 2"
T-005	1/8" pipe thread	Female NPT	3/4", 1", 1 1/2" & 2"
T-006**	1/8" I.D. x 1/4" O.D.	Barbed Compression	3/4"
T-007**	1/4" I.D. x 3/8" O.D.	Barbed Compression	3/4", 1", 1 1/2" & 2"
T-008	3/8" I.D.	Elbow Swivel, Barbed	3/4", 1", 1 1/2" & 2"
T-009	1/2" I.D.	Elbow Swivel, Barbed	3/4", 1", 1 1/2" & 2"
T-011	1/4" I.D.	Elbow Swivel, Barbed	3/4", 1", 1 1/2" & 2"
T-012*	4mm (5/32") I.D.	Elbow Swivel, Barbed	3/4"
T-013*	4mm (5/32") I.D.	Elbow Swivel, Barbed	1/2"
T-014	1/4" I.D.	Barbed	3/4", 1", 1 1/2" & 2"

For flows of 1800 ml/min and above. 1/2" I.D. tubing connectors recommended.

*Use of 4mm connector is limited by flow rate; please contact factory with specifications.

**Cost added for connector.

Tubing Connectors (T-Codes)

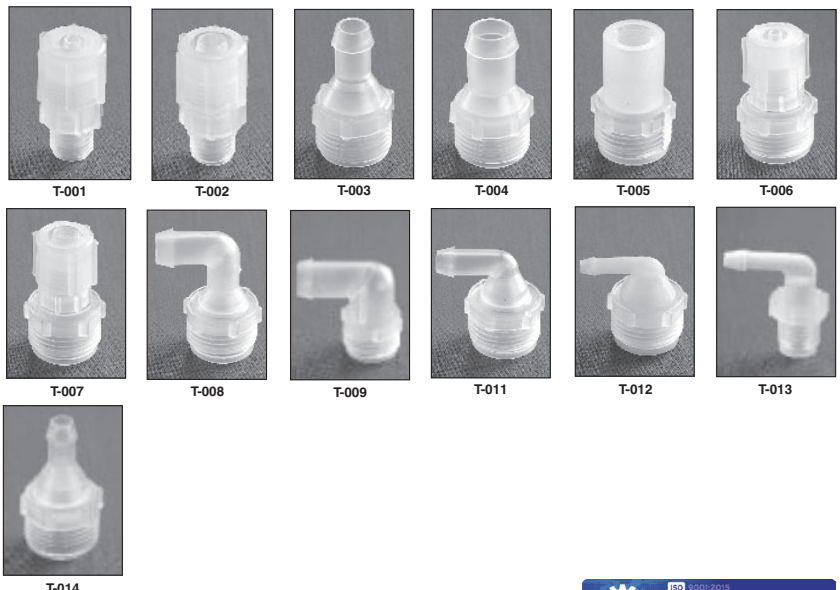

GRI specializes in the adaptation of standard models to meet the ever-changing needs of the Original Equipment Market. Contact us if one of our standard models does not meet your specific requirements.

Motors

- **Speeds**

Standard synchronous motor speeds are 8, 12, 15 and 24 RPM at 60 Hz. Shaded pole motor speeds can be supplied in virtually any speed up to a maximum of 90 RPM.

- **Voltages**

Standard voltages are 115V, 50/60 Hz or 230V, 50/60 Hz. However, the following special voltages are also available: 12 and 24VDC.

- **Designs**

The standard motor is an AC voltage synchronous motor. Depending on the type of mini bellows metering pump, the following motor types are available: shaded pole, stepper and DC.



Shaded Pole Motor

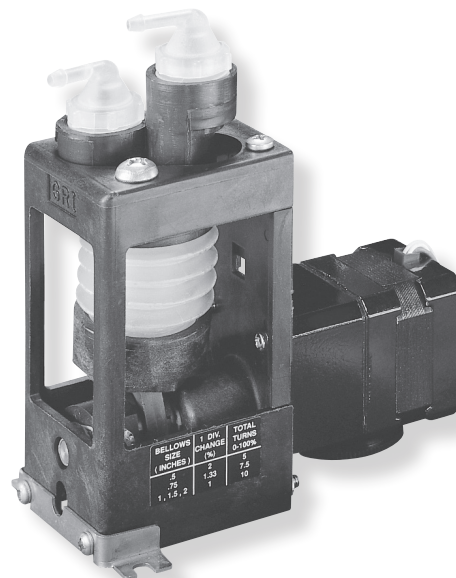

Stepped Motor

Poppet Valves & O-Rings

The standard elastomers for the poppet valves and O-rings are EPT/EPDM and Viton®/Fluoro-elastomer. These elastomers have historically been able to handle the vast majority of the applications in which we've been involved. However, Butyl, Hydrin, Kel-F®, Silicone and Nitrile can be supplied for chemicals requiring such materials.



1/2" Poppet Kit

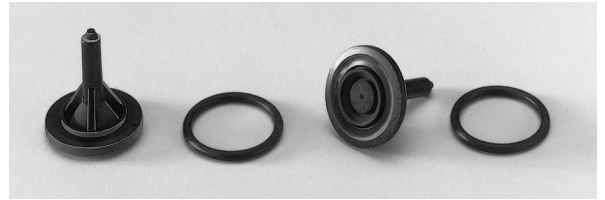

3/4", 1", 1 1/2", and 2" Poppet Kit

Duckbill Valves & O-Rings

Duckbill valves are required in those applications where heavy slurries and fibrous materials are being pumped. Heavy slurries should be flushed from the bellows before pump is shut down. Duckbill valves are available in the same elastomers as the poppet valves.



1/2" Bellows Kit



3/4", 1", 1 1/2", and 2" Bellows Kit

Check and Foot Valves

Check and foot valves are used to maintain a pump's prime or to prevent backflow through a pump in applications with long suction lengths. Check valves can be positioned in-line on the suction or discharge side of the pump; foot valves on the suction side only. To order, refer to the chart on this page.

Elastomer	Single Check Valves		Dual Check Valves	Foot Valves	
	3/8" I.D. Tubing	1/2" I.D. Tubing	3/8" I.D. Tubing	3/8" I.D. Tubing	1/2" I.D. Tubing
EPT/EPDM	15099-002	15099-018	12171-004	15101-002	15101-018
Viton®/Fluoro-elastomer	15099-006	15099-022	—	15101-006	15101-022



Single Check Valve

Opening Pressure: 1 psi (spring loaded)

Materials in Contact with Solution:

- Body, valve seat, connectors, screen (149 Micron) - Polypropylene
- O-rings - EPT/EPDM, Viton®/Fluoro-elastomer
- Spring - Hastelloy® C

Options: 1/2" or 3/8" I.D. tubing connectors



Dual Check Valve

Opening Pressure: .2 psi (two poppets located in series)

Materials in Contact with Solution:

- Body, connectors - Polypropylene
- Poppet valves & O-rings — EPT/EPDM



Foot Valve

Opening Pressure: 1 psi (spring loaded)

Materials in Contact with Solution:

- Body, valve seat, connectors, screen (149 Micron) - Polypropylene
- O-rings - EPT/EPDM, Viton®/Fluoro-elastomer
- Spring - Hastelloy® C

Options: 1/2" or 3/8" I.D. tubing connectors

Anti-Siphon Spring Kits

Anti-siphon springs are available to springload poppet valves. Use of these springs produces more positive shutoff of poppet valves and permits use of the pump where there is a positive pressure on the suction side. Available for the 1", 1 1/2"

and 2 1/2" models. To order, select the proper spring material and O-ring by referring to the Chemical Resistance Section. The appropriate kit can then be chosen based on the blow-off pressure (PSI) required.



(Valve extension required only on suction port.)

Spring	O-Ring (Elastomer) Material			
	EPT/EPDM		Viton®/Fluoroelastomer	
	.5 PSI	5 PSI	.5 PSI	5 PSI
Monel	02501-112	02501-113	02501-124	02501-525
316 S.S.	02501-114	02501-115	02501-126	02501-127
Hastelloy® C	02501-116	02501-117	02501-128	02501-129

Kits include valve extension for suction port. Kits do not include poppet valve.

Replacement Kits

Mini Bellows

Bellows Module Kits



Proper selection of bellows module and poppet valve replacement kits depends on the X-code of the model number and not on the pump type (i.e. single, tandem).

Materials	Bellows Size				
	1/2"	3/4"	1"	1 1/2"	2"
EPT/EPDM	02501-315	02501-356	02501-357	02501-358	02501-359
Viton®/ Fluoroelastomer	02501-314	02501-376	02501-377	02501-378	02501-379

Crank Kits



1. Proper selection of crank replacement kits depends on the position of the module in relation to the motor.
2. Use diagram below the chart to determine the location of the crank being replaced. When proper size and location are decided upon, use crank kits chart to obtain kit number for ordering.

Bellows Size	Chart Location	Kit Part Number
1/2"	1, 3	02501-345
3/4"	1, 3	02501-346
1", 1 1/2" & 2"	1, 3	02501-344
1/2"	2	02501-348
3/4"	2	02501-349
1", 1 1/2" & 2"	2	02501-347

MOTOR 1

MOTOR 2 3

Poppet Valve and O-Ring Kits

The standard elastomers for the poppet valves and O-rings are EPT/EPDM and Viton®/Fluoroelastomer. These elastomers have historically been able to handle the vast majority of the applications in which we've been involved. However, Butyl, Hydrin, Kel-F®, Silicone and Nitrile can be supplied for chemicals requiring such materials.



1/2", Poppet Kit

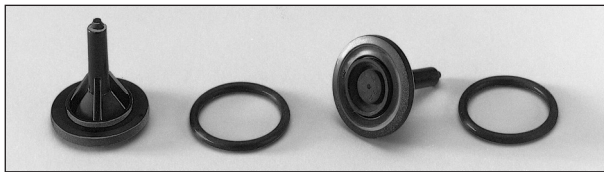

3/4", 1", 1 1/2" and 2" Poppet Kit

Materials	3/4" Bellows	1" Bellows	1 1/2" Bellows	2" Bellows
Butyl	02500-604 (X-111)	02500-604 (X-111)	02500-604 (X-111)	—
EPT/EPDM	02500-605 (X-112)	02500-605 (X-112)	02500-605 (X-112)	02500-605 (X-142)
Hydrin	02500-606 (X-113)	02500-606 (X-113)	02500-606 (X-113)	—
Kel-F®	02500-607 (X-114)	02500-607 (X-114)	02500-607 (X-114)	—
Viton®/Fluoroelastomer	02500-609 (X-116)	02500-609 (X-116)	02500-609 (X-116)	02500-609 (X-116)
Silicone	02500-610 (X-118)	02500-610 (X-118)	02500-610 (X-118)	—
Nitrile	02500-611 (X-119)	02500-611 (X-119)	02500-611 (X-119)	—

Duckbill Valve and O-Ring Kits

Duckbill valves are required in those applications where heavy slurries or fibrous materials are being pumped. Heavy slurries should be flushed from the bellows before the pump is shut down. The standard elastomers are EPT/EPDM and Viton®/Fluoroelastomer. However, Butyl, Hydrin, Kel-F®, Silicone and Nitrile can be supplied.

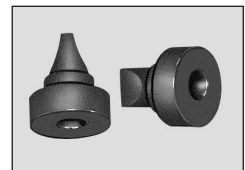

1/2", Bellows Kit

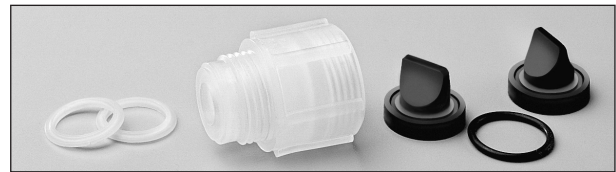

3/4", 1", 1 1/2" and 2" Bellows Kit (Valve extension required only on suction port.)

Materials	3/4" Bellows	1" Bellows	1 1/2" Bellows	2" Bellows
Butyl	02500-327 (X-031)	02500-327 (X-031)	02500-327 (X-031)	—
EPT/EPDM	02500-322 (X-032)	02500-322 (X-032)	02500-322 (X-032)	02500-322 (X-152)
Hydrin	02501-528 (X-033)	02501-528 (X-033)	02501-528 (X-033)	02501-528 (X-153)
Kel-F®	02500-355 (X-034)	02500-355 (X-034)	02500-355 (X-034)	02500-355 (X-154)
Viton®/Fluoroelastomer	02500-319 (X-036)	02500-319 (X-036)	02500-319 (X-036)	02500-319 (X-156)
Silicone	02500-324 (X-038)	02500-324 (X-038)	02500-324 (X-038)	02500-324 (X-158)
Nitrile	02500-320 (X-039)	02500-320 (X-039)	02500-320 (X-039)	02500-320 (X-159)

Tubing Connector Kits

Connectors are made from polypropylene and are designed for use with soft vinyl and similar tubing.

T-Code	Kit Part Number
T-001	02500-312
T-002	02500-635
T-003	02500-352
T-004	02500-353
T-005	02500-258

T-Code	Kit Part Number
T-006	02500-259
T-007	02500-260
T-008	02500-261
T-009	02500-354

T-Code	Kit Part Number
T-011	02501-337
T-012	02501-246
T-013	02501-541
T-014	02501-673

Note: Kit includes two connector nuts and connectors.

Typical Dimensions

Mini Bellows

Single Model

Weight of single mini bellows pump: 0.67 lb.

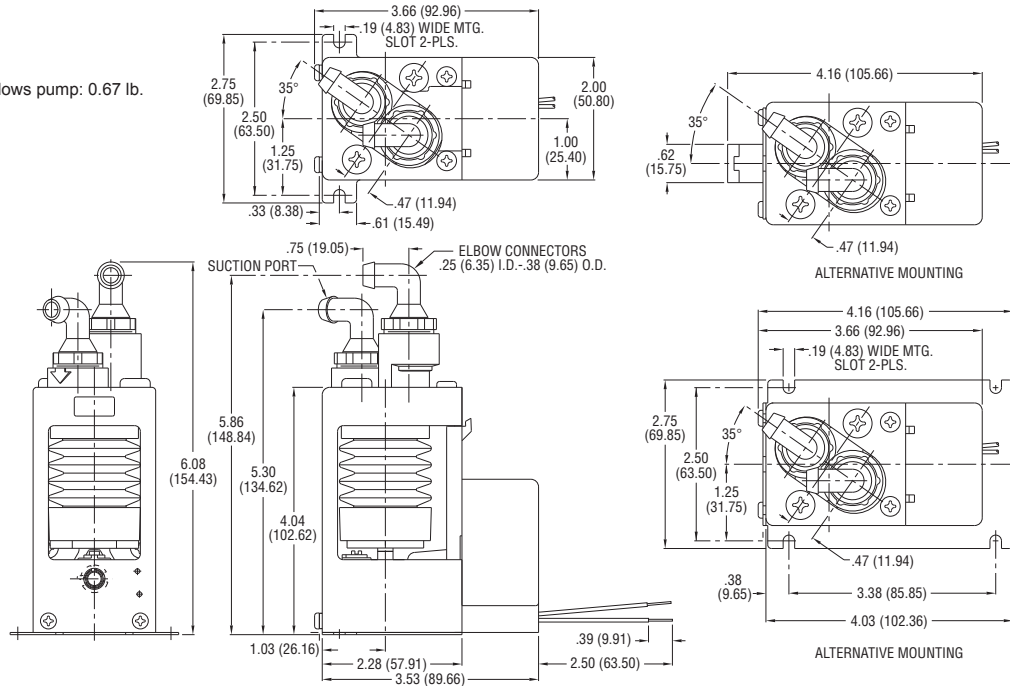

Single T-Head Model

Weight of single mini bellows pump: 0.67 lb.

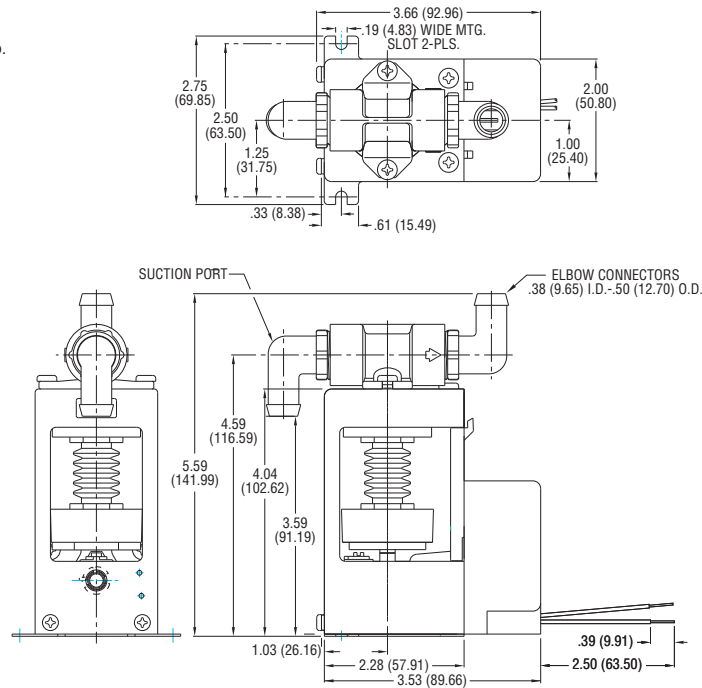

Dimensions in Inches
 (Dimensions in Millimeters)



Typical Dimensions

Mini Bellows

2-Tandem Model

Weight of 2-tandem mini bellows pump: 1.0 lb.

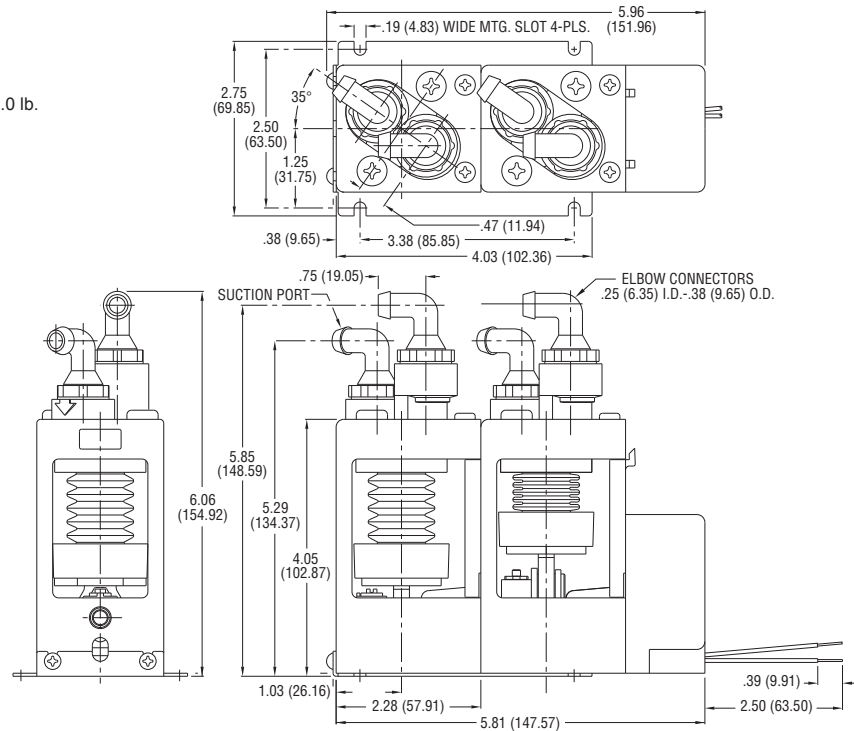

2-Tandem, T-Head Model

Weight of 2-tandem mini bellows pump: 1.0 lb.

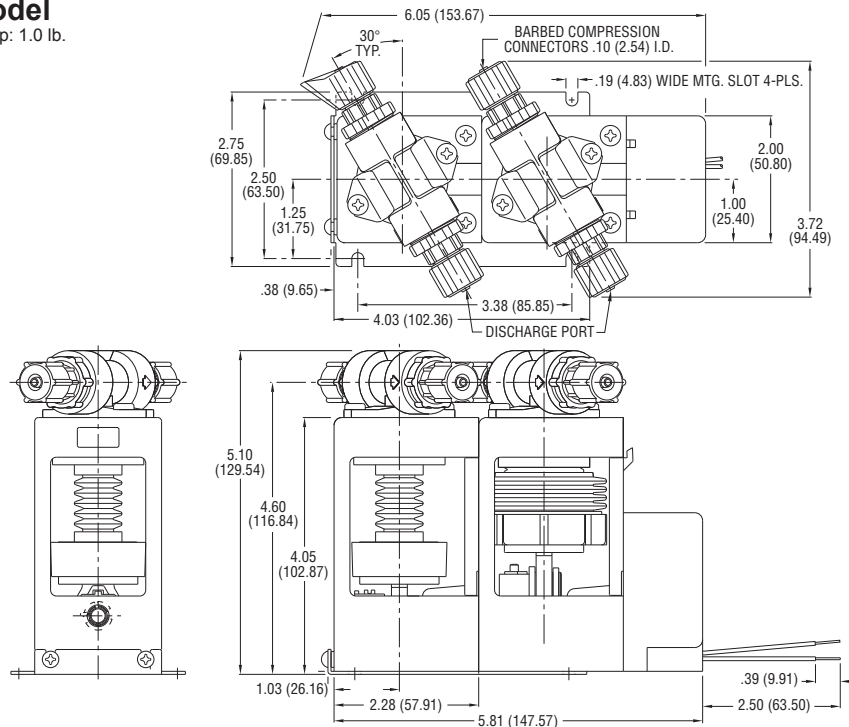

Dimensions in Inches
(Dimensions in Millimeters)



EXPLODED VIEW – MINI BELLOWS METERING PUMP

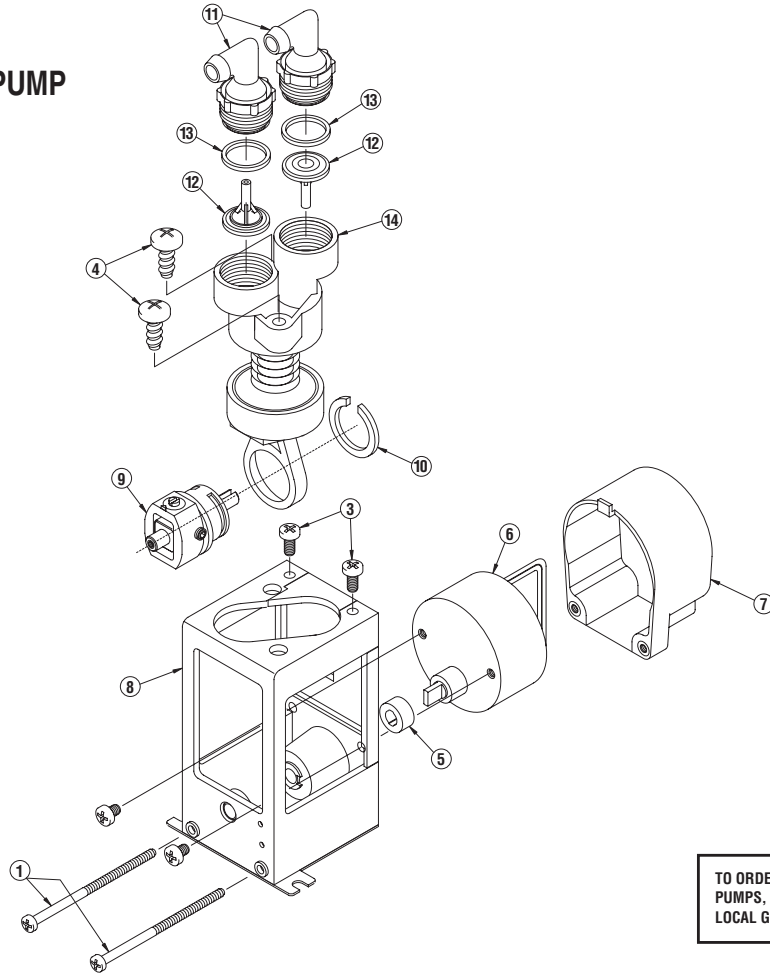

TO ORDER REPLACEMENT
PUMPS, OR KITS, CALL YOUR
LOCAL GRI DISTRIBUTOR.